

MERIDIAN CENTRAL ESTATE - STAGE 31

BROWN PROPERTY GROUP

CITY OF CASEY

CONSTRUCTION NOTES

SITE MANAGEMENT

- A1. Prior to commencement of works on site, the contractor must ensure that all matters relating to the Occupational Health & Safety Act 2004, including all relevant regulations, have been addressed. In particular, the required notifications must be conveyed to the Victorian Workcover Authority - Health & Safety division with respect to trenching operations. Details of the contractors occupational health & safety procedures must be lodged with the superintendent prior to commencement of works.
- A2. All native trees & shrubs to be retained unless road construction necessitates their removal or removal is directed by the engineer. A town planning permit is required for the removal of native trees & / or vegetation. The removal or retention of any existing trees must be in accordance with the approved landscape plan, or else approval will be required from the City of Casey landscape approvals officer.
- A3. Existing dam or watercourses to be excavated to a firm base & backfilled as specified. Consulting engineer to be notified when the dam or watercourses are excavated to a firm base. No filling is to be placed prior to dams being inspected & levels taken. Backfilling is to be carried out to the satisfaction of the Council supervising engineer.
- A4. Prior to commencement of works, the contractor must submit a Site Management Plan (SMP) to the consultant for approval. The contractor must comply with the recommendations of the Environment Protection Authority publication No.275 "Construction techniques for sediment pollution control". Appropriate siltation control is to be maintained throughout the construction & maintenance period of the works.
- A5. Provide temporary safety barrier fence (Farm Fence as per MW Std Dwg 7251/4/203) along extent of outfall drain where the drain is greater than 1.5m in depth & side slopes are steeper than 1 in 3. Safety fence to remain until permanent underground drainage is installed.
- A6. Contractor to remove existing irrigation & drainage pipes & pits encountered on site. Trenches to be backfilled in accordance with notes C2 & C3.
- A7. An environmental management plan (EMP) must be submitted to and approved by Council prior to the commencement of any works on site and all works must be carried out in accordance with this EMP.
- A8. A traffic management plan (TMP) must be submitted to, and approved by Council prior to the commencement of any works on site and all traffic management must be carried out in accordance with this TMP.

GENERAL

- B1. All works to be carried out in accordance with AS2124-1992 general conditions of contract & the City of Casey and EDCM current specification & standard drawings & to the satisfaction of the City of Casey works supervisor.
- B2. Council to be notified two (2) clear days prior to commencement of works.
- B3. Before commencement of works on trenches in excess of 1.5m deep, the civil contractors construction supervisor must give notice in writing of such proposals to Worksafe Victoria in accordance with Part 5.1, Division 4 of the Occupational Health & Safety regulations (2007) & undertake safety precautions in trenching operations in accordance with Workcover's code of practice (1988).
- B4. Lots to be graded (1 in 150 min slope) & left clean to the satisfaction of the engineer. Finished levels to be compatible with lots adjoining this stage.
- B5. On completion the contractor is responsible for the removal of all rubbish & spoil from site. No surplus trees, vegetation or other material is to be burnt on site.
- B6. Reserves to be free draining & to be left in a condition satisfactory to the City of Casey works supervisor.
- B7. Where works are in the vicinity of existing services these services are to be located & the various authorities notified prior to the commencement of works.
- B8. All TBM's & control points are to be maintained & protected at all times during construction. Should any marks be disturbed, the contractor will immediately notify the consultant to arrange re-instatement at the contractors expense.
- B9. Provide painted piling fence along any boundary common to lots & municipal reserves as per Council Std. Dwg. S-706. Pailings to be on the reserve side.
- B10. As constructed plans and electronic asset information in D-Spec and R-Spec format must be submitted to Council prior to practical completion.

ROADWORKS

- C1. 100a agricultural pipe drains (MPA standard drawing EDCM 202) to be placed behind all kerb & channel & buffer pitches & where directed by the engineer.
- C2. Filling in all properties & road reserves is to be carried out using approved clay fill. Top soil & all vegetable matter to be stripped from site prior to filling. All filling to be carried out in accordance with AS3798-2007 and the geotechnical report. Level 1 inspection and testing to be carried out in accordance with AS3798-2007 Section 8.2. A fill report must be submitted to the Consultant, showing from a NATA registered soil testing laboratory.
- C3. Importing Fill- All imported fill must be tested by a NATA approved laboratory to ensure it is suitable for use on site, & any contaminants are within accepted levels. Under no circumstances should fill material enter or leave the site without the permission of the supervising engineer & Council works supervisor, prior to it being appropriately tested. All vehicles transporting fill material to & from the site must have appropriate measures in place to ensure that material does not get onto roads & into stormwater systems & natural waterways.
- C4. Batters to be 1 in 5 for fill & 1 in 3 for cut unless noted otherwise.
- C5. Cut batters are to be grassed & mulched with a mixture of chopped grass, straw & bitumen emulsion.
- C6. Where cut batters exceed 700mm an additional 300mm berm shall be formed behind footpath.

- C7. Access ramps are to be constructed where cut batters exceed 1.0m. They are to be graded 1 in 10 for the first 2.5m from the back of path & then at a maximum of 1 in 4 to natural surface.
- C8. The water conduit offset from the lot boundary is given on the water reticulation plan. The contractor must construct conduits to accord with the given offset & ensure that the concrete marks the kerb & footpath exactly above the conduit.
- C9. Irrigation conduits are to be DN100 DWV PVC installed beneath the pavement and/or capping layer, if present. Locations are to be marked using a green dot spray painted on the top of kerb.
- C10. All footpaths are to be 125mm thick 25MPa concrete with SL72 mesh centrally located in accordance with the MPA standard drawing EDCM 401.
- C11. NBN Co to be notified seven (7) days prior to concrete works being placed.
- C12. Electrical distribution pits within footpaths are to be a minimum of 300mm within the edge of the path. Concrete is to be placed around distribution pits to a minimum depth of 200mm.
- C13. All street signs to be constructed & erected to current City of Casey standards including logo. Court street names are to show court name only.
- C14. Traffic control signs, markings & delineators to be installed in accordance with AS1742.2. All line marking is to be long life road marking, with longitudinal lines in thermoplastic & transverse markings in cold applied.
- C15. Driveways to be constructed in accordance with the MPA standard drawings EDCM 501 & EDCM 502. Single driveways to be a minimum 3.5m wide & to be offset 0.75m from side boundary or easement unless otherwise shown.
- C16. Kerb transition to take place in the minor street over a 2.0m length from either the tangent point or TP pit.
- C17. Existing road works to be reconstructed as required to provide, without discontinuity, a connection in accordance with design levels & grades.
- C18. Provide 2.5m wide shared footpath through reserves as shown on a curvilinear alignment to the satisfaction of the engineer.
- C19. Tactile ground surface indicators (TGSi) are to be installed at all pram crossings & pedestrian cross points in accordance with AS1428.4 : 2002 & MPA standard drawing EDCM 403.
- C20. If any existing substandard filling is encountered on the site it must be removed and replaced with approved fill material properly compacted to Council requirements. A geo-technical report must be submitted showing details of depth, type of material and density of the fill areas concerned.

DRAINAGE

- D1. Drainage & pits to be set out from offsets shown rather than from centreline pipe chainages. Centreline of pits at TP's to be offset 1.00m.
- D2. Terra Firma or fibreglass type pit lids are required for all drainage pits & all grates for pits are to be Class D, to comply with AS3996 unless otherwise shown. All drainage works are to be constructed to council specifications.
- D3. All pipes up to and including 750mm in diameter shall be rubber ring jointed (RRJ). Pipes above this size may be flush jointed with external sealing bands. For pipes greater than 900mm and changes in direction between 2 connecting pipes exceeding 10° construct segmented curves using splayed pipes with bandage joints, having deflections within the manufacturer's specification.
- D4. All pipes to be Class 2 R.C. rubber ring joint unless noted otherwise. PVC pipes to be Class SH unless specified.
- D5. Pipe trenches beneath the road pavement, footpath or within 150mm of the kerb & channel to be backfilled with 20mm Class 3 FCR in 150mm layers.
- D6. Property inlets to be constructed as per MPA standard drawing EDCM 701 - EDCM 704.
- D7. All proposed drainage stubs to be blanked off at end of pipe with timber planks to the satisfaction of the supervising engineer.
- D8. A CCTV report must be provided for all drainage lines prior to issue of practical completion.

PAVEMENT

- E1. Modification of the pavement requires approval by the City of Casey works supervisor.

DRAWING INDEX

DRAWING No.	TITLE	REVISION
1801767-31-001	COVER SHEET	B
1801767-31-002	TYPICAL ROAD CROSS SECTIONS AND GENERAL DETAILS	B
1801767-31-003	PAVEMENT MAKEUP AND RETAINING WALL DETAILS	A
1801767-31-010	LAYOUT PLAN (SHEET 1 OF 2)	B
1801767-31-011	LAYOUT PLAN (SHEET 2 OF 2)	A
1801767-31-015	INTEGRATED WATER MANAGEMENT LAYOUT PLAN	B
1801767-31-016	INTEGRATED WATER MANAGEMENT DETAILS (SHEET 1 OF 2)	A
1801767-31-017	INTEGRATED WATER MANAGEMENT DETAILS (SHEET 2 OF 2)	A
1801767-31-100	ROAD LONGITUDINAL SECTIONS PORTOBELLO BOULEVARD	A
1801767-31-101	ROAD LONGITUDINAL SECTIONS BURLINA BOULEVARD	A
1801767-31-102	ROAD LONGITUDINAL SECTIONS CHITTAGONG DRIVE & GININ STREET	A
1801767-31-200	ROAD CROSS SECTIONS PORTOBELLO BOULEVARD (SHEET 1 OF 2)	A
1801767-31-201	ROAD CROSS SECTIONS PORTOBELLO BOULEVARD (SHEET 2 OF 2)	A
1801767-31-202	ROAD CROSS SECTIONS BURLINA BOULEVARD	A
1801767-31-203	ROAD CROSS SECTIONS CHITTAGONG DRIVE	A
1801767-31-204	ROAD CROSS SECTIONS GININ STREET	A
1801767-31-300	INTERSECTION DETAILS (SHEET 1 OF 4)	A
1801767-31-301	INTERSECTION DETAILS (SHEET 2 OF 4)	B
1801767-31-302	INTERSECTION DETAILS (SHEET 3 OF 4)	B
1801767-31-303	INTERSECTION DETAILS (SHEET 4 OF 4)	B
1801767-31-350	SIGNAGE & LINE MARKING PLANS	B
1801767-31-400	DRAINAGE LONGITUDINAL SECTIONS (SHEET 1 OF 5)	A
1801767-31-401	DRAINAGE LONGITUDINAL SECTIONS (SHEET 2 OF 5)	A
1801767-31-402	DRAINAGE LONGITUDINAL SECTIONS (SHEET 3 OF 5)	A
1801767-31-403	DRAINAGE LONGITUDINAL SECTIONS (SHEET 4 OF 5)	A
1801767-31-404	DRAINAGE LONGITUDINAL SECTIONS (SHEET 5 OF 5)	A
1801767-31-405	PIT SCHEDULE	A

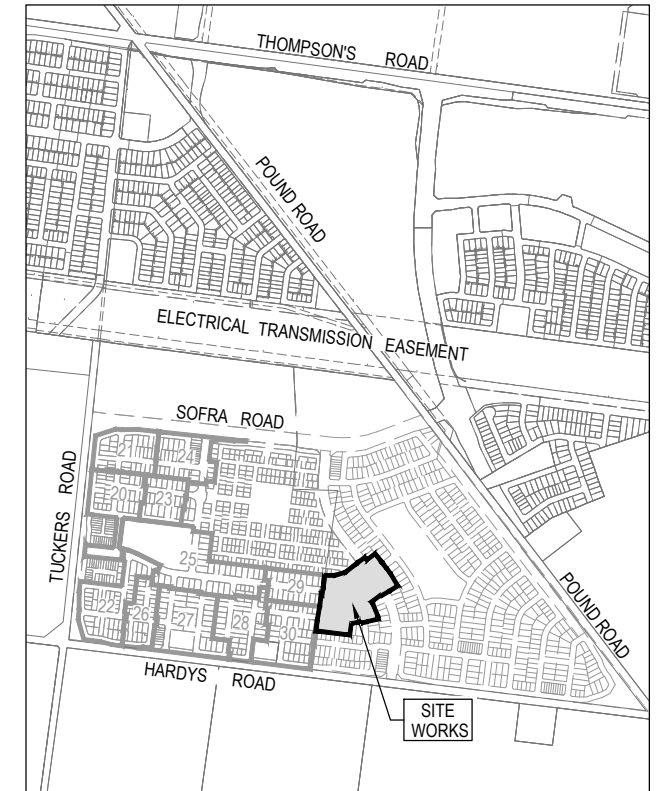

SITE PLAN

NOT TO SCALE

MELWAY REF: 135 F4

Survey Origin:

Coordinates are on a local plane datum based upon MGA2020 Zone 55 bearings and truncated MGA2020 Zone 55 co-ordinates at PM77. Heights are to AHD vide Permanent Mark PM 56 (Cranbourne) RL 26.71 Bearing Datum is MGA2020 Zone 55 which has been derived by our GPSnet Survey.

Plane Grid Coordinates to MGA2020 Zone 55 Grid Coordinates Conversion.

(PLANE SHIFT) Add + 353,823.586 to Eastings
Add +5,780,840.520 to Northings
(APPLY SCALE FACTOR) Scale by 0.999846 at point PM77

ISSUED FOR CONSTRUCTION

REV	DESCRIPTION	DATE	DRN.	APP.	REV	DESCRIPTION	DATE	DRN.	APP.
B	DRAWING INDEX UPDATED	28.03.22	M.F.	M.F.					
A	ISSUED FOR CONSTRUCTION	24.02.22	M.F.	M.F.					



Designed Date
E. BARCHAM
02.08.2021

Drawn
N. TABUENA

Approved Date
M. FELICIANO
02.08.2021

PS Number
PS84826W



Project Details
MERIDIAN CENTRAL ESTATE
STAGE 31
CITY OF CASEY

Drawing Title
COVER SHEET

Sheet 01 of 27

Scale

Project Ref
1801767

Stage No
31

Drawing No
001

Rev
B



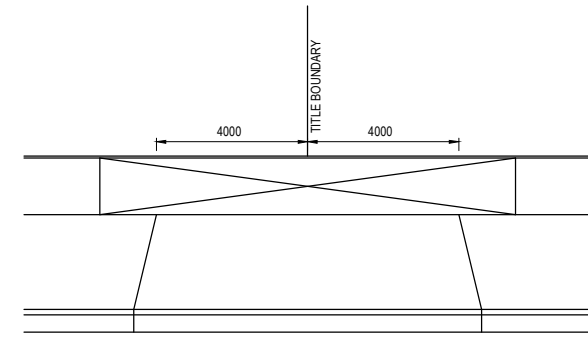
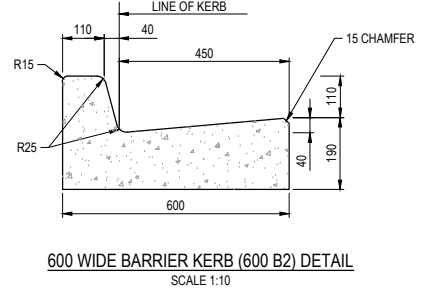
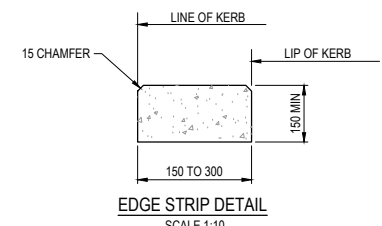
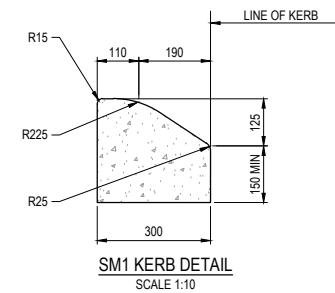
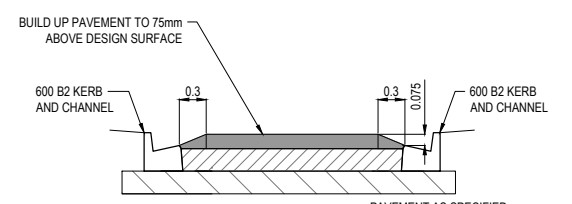
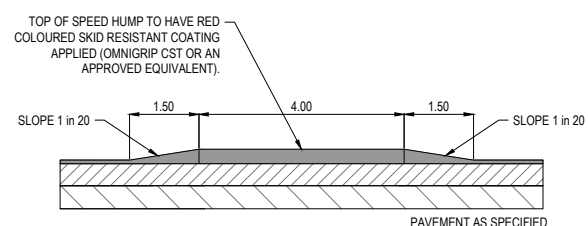
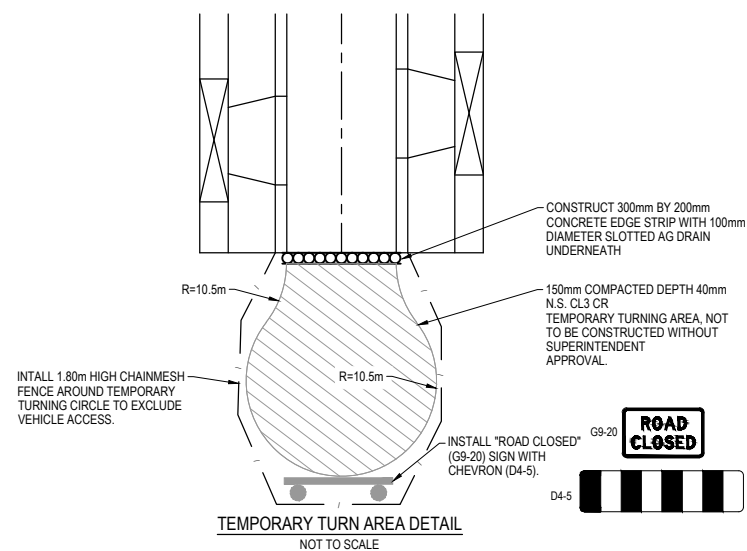
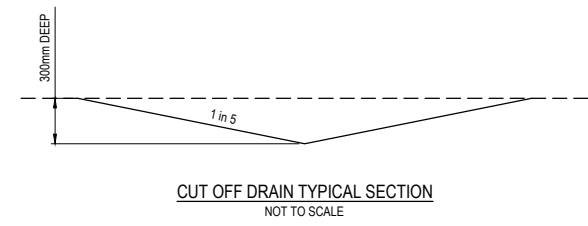
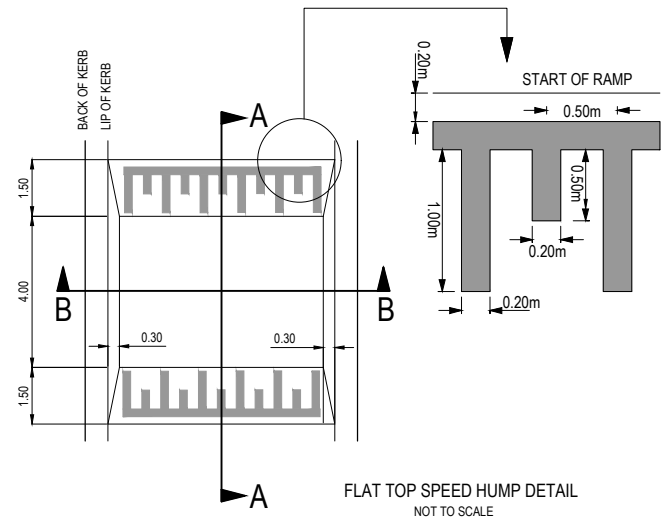
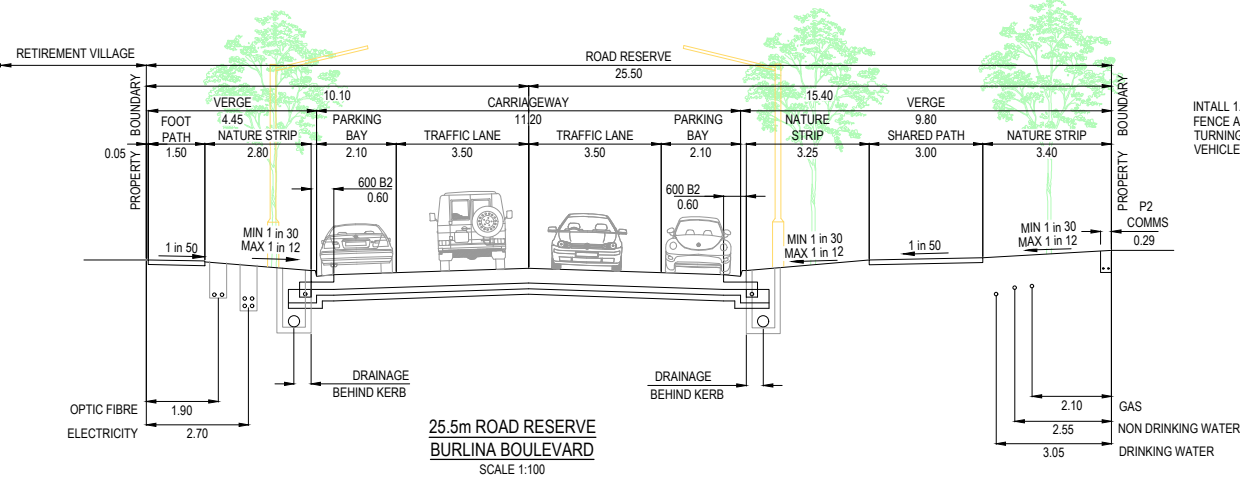
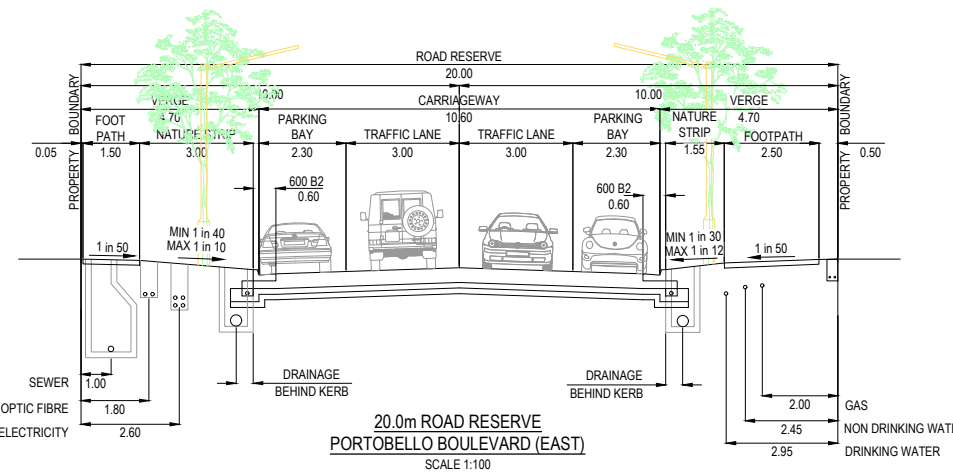
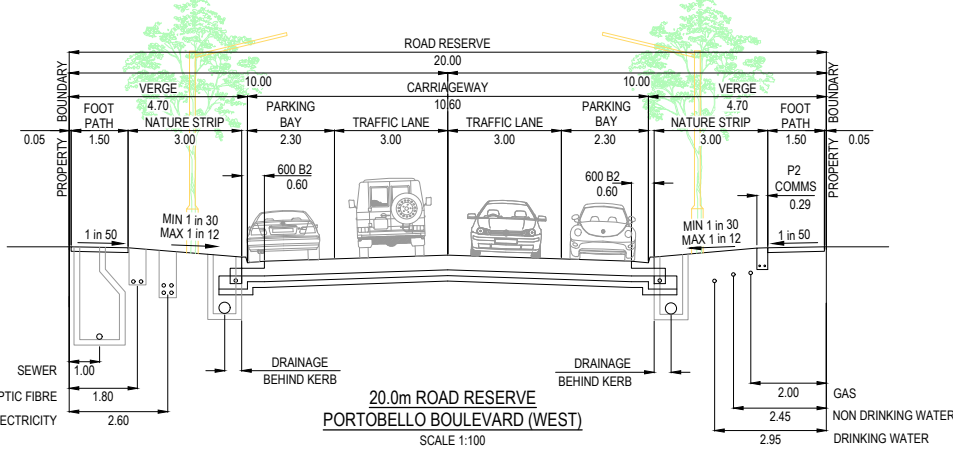
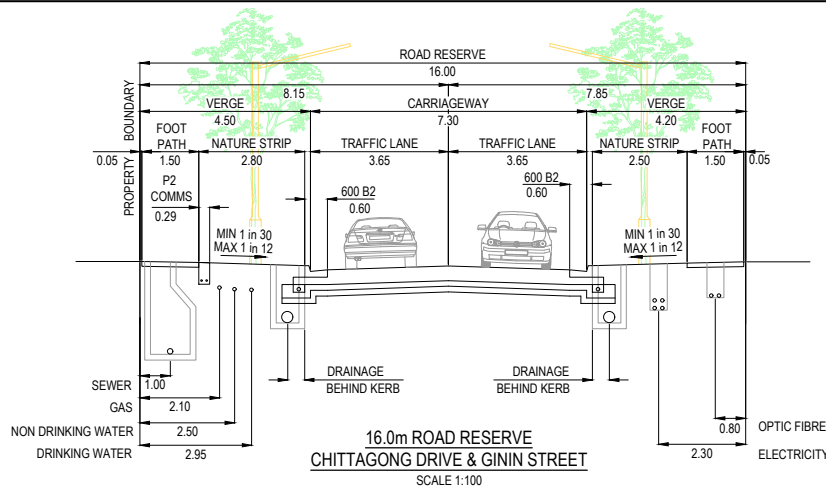

NOTES
1. REFER TO EDM 502 FOR FURTHER DETAILS

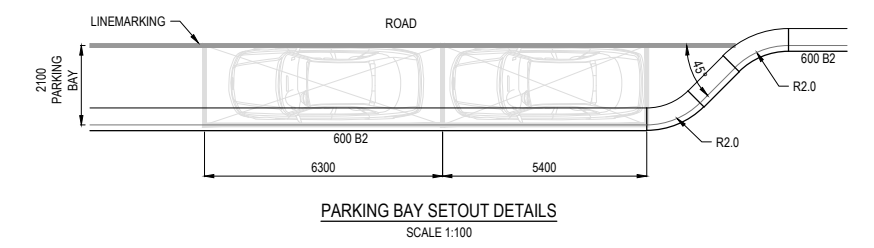
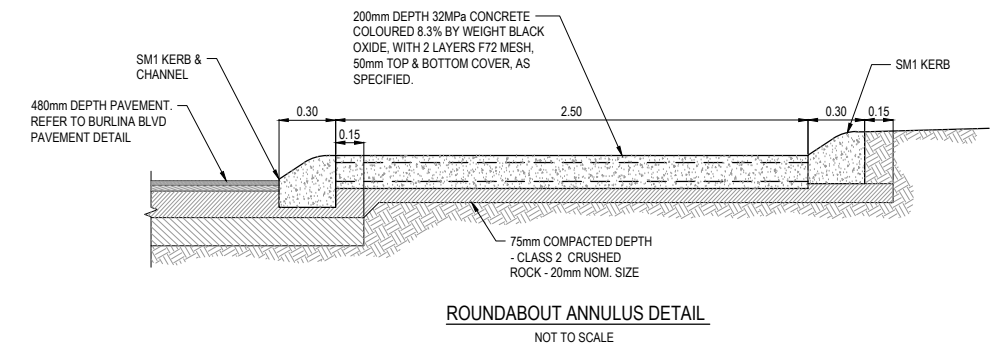

ISSUED FOR CONSTRUCTION

REV	DESCRIPTION	DATE	DRN.	APP.	REV	DESCRIPTION	DATE	DRN.	APP.
B	RAISED PRIORITY CROSSING REMOVED	28.03.22	M.F.	M.F.					
A	ISSUED FOR CONSTRUCTION	24.02.22	M.F.	M.F.					



Designed By: E. BARCHAM
Date: 02.08.2021
Drawn By: N. TABUENA
Approved By: M. FELICIANO
Date: 02.08.2021
PS Number: PS848726W



Project: MERIDIAN CENTRAL ESTATE
Stage: 31
City: CITY OF CASEY
Drawing Title: TYPICAL ROAD CROSS SECTIONS AND GENERAL DETAILS

Sheet 02 of 27
Scale: AS SHOWN
Project Ref: 1801767
Stage No: 31
Drawing No: 002
Rev: B

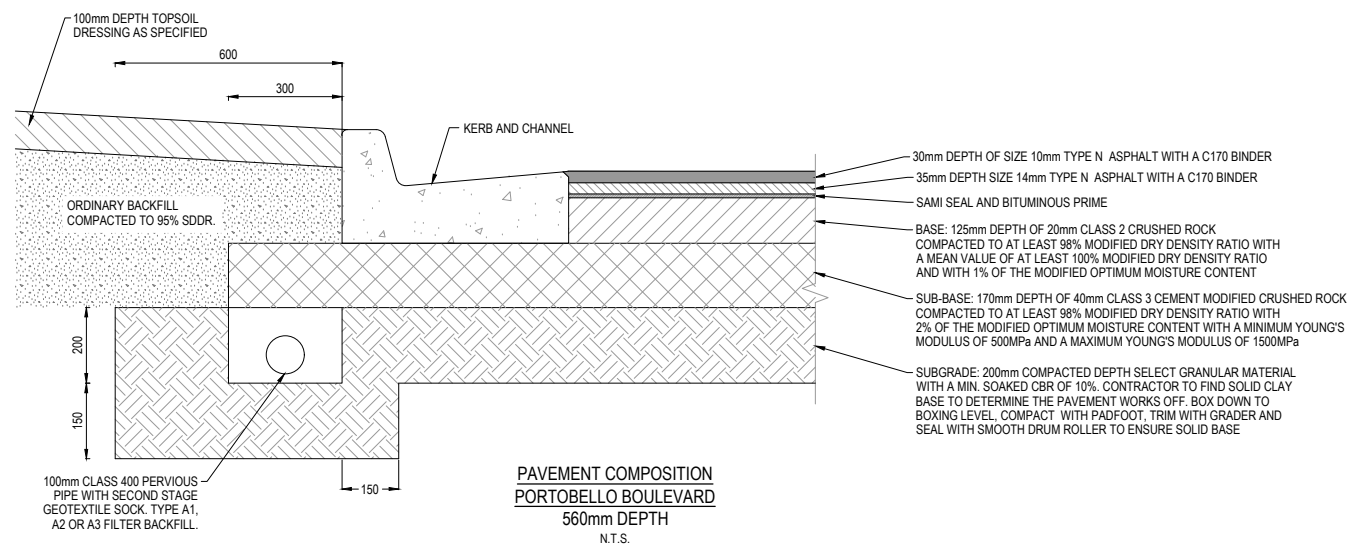

PAVEMENT COMPOSITION
PORTOBELLO BOULEVARD
560mm DEPTH
N.T.S.

REFER STANDARD DRAWING
EDCM 202 FOR DETAILS.

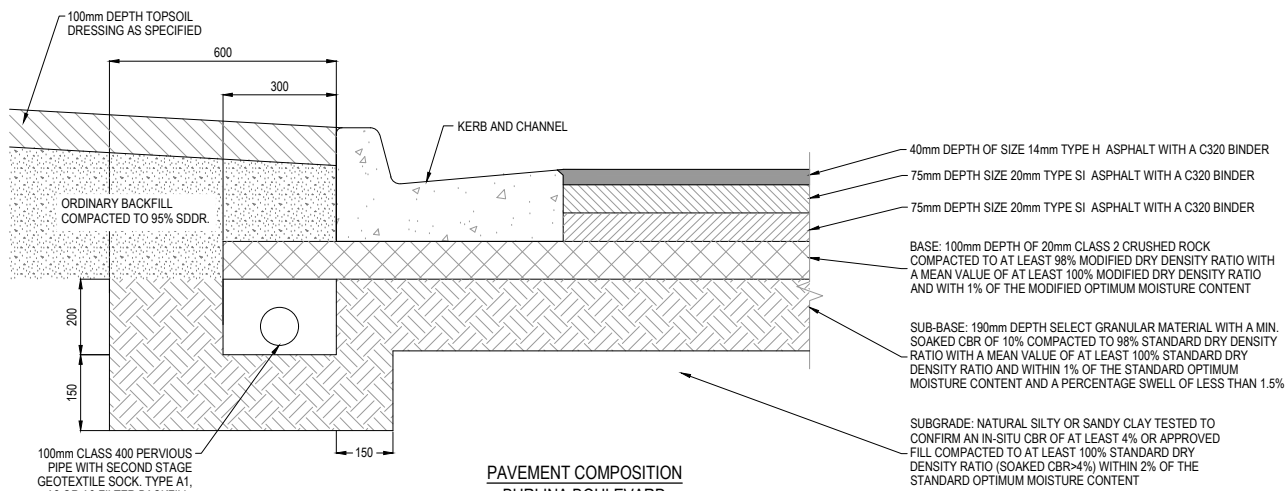

PAVEMENT COMPOSITION
BURLINA BOULEVARD
480mm DEPTH
N.T.S.

REFER STANDARD DRAWING
EDCM 202 FOR DETAILS.

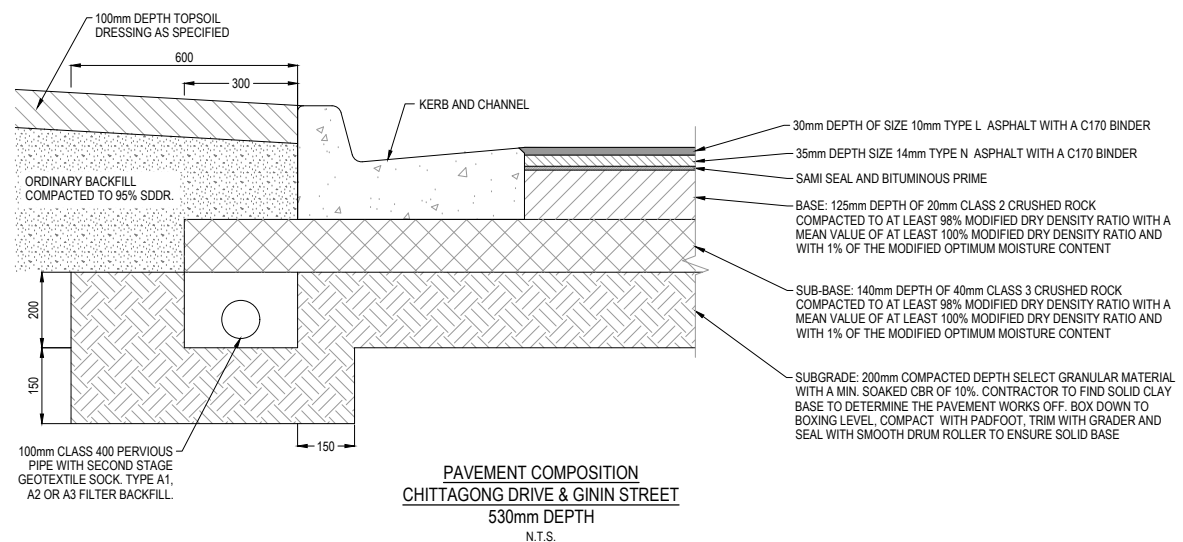

PAVEMENT COMPOSITION
CHITTANGONG DRIVE & GININ STREET
530mm DEPTH
N.T.S.

REFER STANDARD DRAWING
EDCM 202 FOR DETAILS.

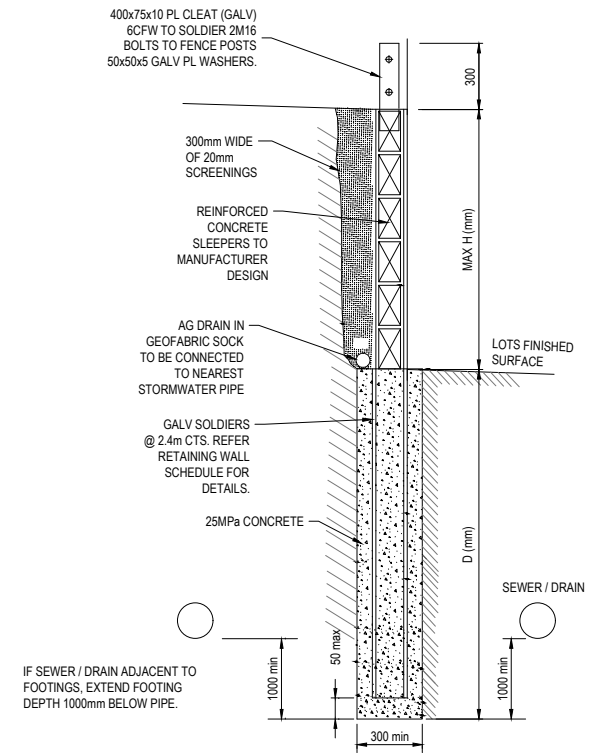

CONCRETE SLEEPER
RETAINING WALL DETAILS
NTS

CONCRETE SLEEPER RETAINING WALL SCHEDULE

HEIGHT - H(mm)	DEPTH - D(mm)	SOLDIERS SIZE @ 2.4m CTS
600	900	100 UC 14.8
800	1200	100 UC 14.8
1000	1500	100 UC 14.8

Dmin TO BE GREATER OF THAT SHOWN ABOVE OR 1000mm BELOW ADJACENT SEWER / DRAINAGE

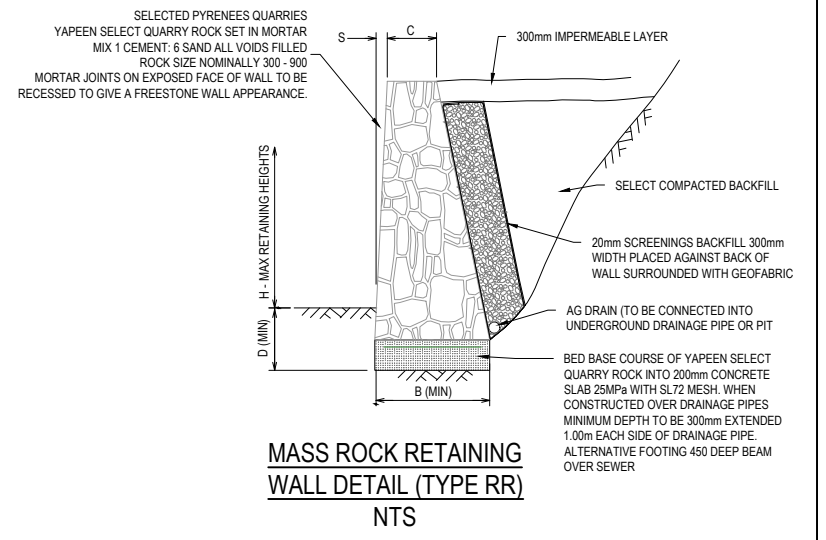

MASS ROCK RETAINING
WALL DETAIL (TYPE RR)
NTS

MASS ROCK RETAINING WALL SCHEDULE

MAX WALL HEIGHT-H(mm)	FOUNDING DEPTH-D(mm)	BASE WIDTH - B(mm)	FRONT FACE SETBACK-S (mm)	CREST WIDTH-C(mm)
400	400	450	15	300
500	400	500	15	300
600	400	500	30	300
800	400	600	30	300
1000	400	700	30	300

RETAINING WALL NOTE R.1
a. WHERE FOOTPATH ABUTS RETAINING WALL CONTINUE CONCRETE UP TO BASE OF RETAINING WALL.

FOOTING NOTE F.2
a. TOE OF WALL SHALL PENETRATE THROUGH ANY FILL MATERIAL & THE NATURAL SILT SOILS TO BE FOUND AT LEAST 100mm INTO THIS UNDERLYING NATURAL STILL CLAY OR WEATHERED ROCK.
ALL EXCAVATIONS SHALL HAVE FOUNDING DEPTHS AND BEARING CAPACITY APPROVED BY THE ENGINEER OR BUILDING SURVEYOR BEFORE CONCRETE IS PLACED.
FOOTING EXCAVATIONS WHICH ARE DEEPENED TO PENETRATE THROUGH UNSUITABLE SOILS SHALL BE BACKFILLED UP TO UNDERSIDE OF FOOTINGS WITH 15 MPa BLINDING CONCRETE.
b. ALL EXCAVATION FOUNDING SURFACES SHALL BE LEVEL (NOT INCLINED) CLEAN CUT & FREE OF MUD OR WATER.
c. ALL SEEPAGE INFLOW SHALL BE REMOVED BEFORE PLACEMENT OF CONCRETE.
d. FOOTINGS SHALL BE FOUND IN STIFF NATURAL CLAY HAVING A SAFE BEARING CAPACITY OF 150KPa.

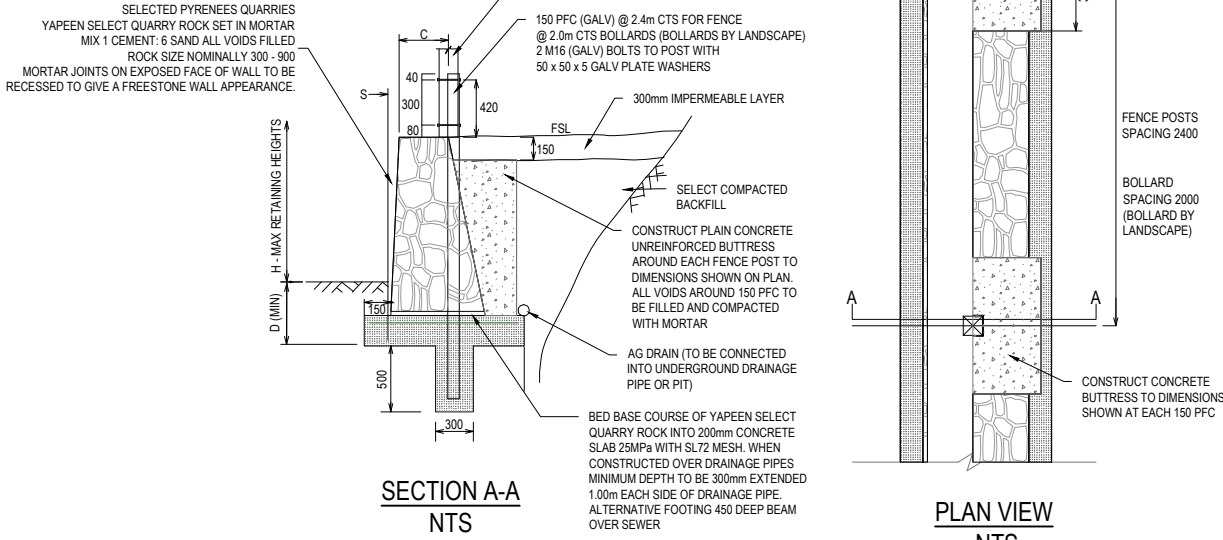

MASS ROCK RETAINING WALL DETAIL WITH
PALING TIMBER FENCE (TYPE RR) OR BOLLARD
(BOLLARD BY LANDSCAPE)
NTS

ISSUED FOR
CONSTRUCTION

© COPYRIGHT All rights reserved
Beveridge Williams & Co. Pty Ltd has granted a licence to the principle to use this document for its intended purpose.
No unauthorised copying is permitted.

REV	DESCRIPTION	DATE	DRN	APP	REV	DESCRIPTION	DATE	DRN	APP
A	ISSUED FOR CONSTRUCTION	24.02.22	M.F	M.F					



Designed Date
E. BARCHAM
02.08.2021

Drawn
N. TABUENA

Approved Date
M. FELICIANO
02.08.2021

PS Number
PS848726W



Project Details
MERIDIAN CENTRAL ESTATE
STAGE 31
CITY OF CASEY

Drawing Title
PAVEMENT MAKEUP AND
RETAINING WALL DETAILS

Sheet 03 of 27

Scale
AS SHOWN

Project Ref
1801767

Stage No
31

Drawing No
003

Rev
A

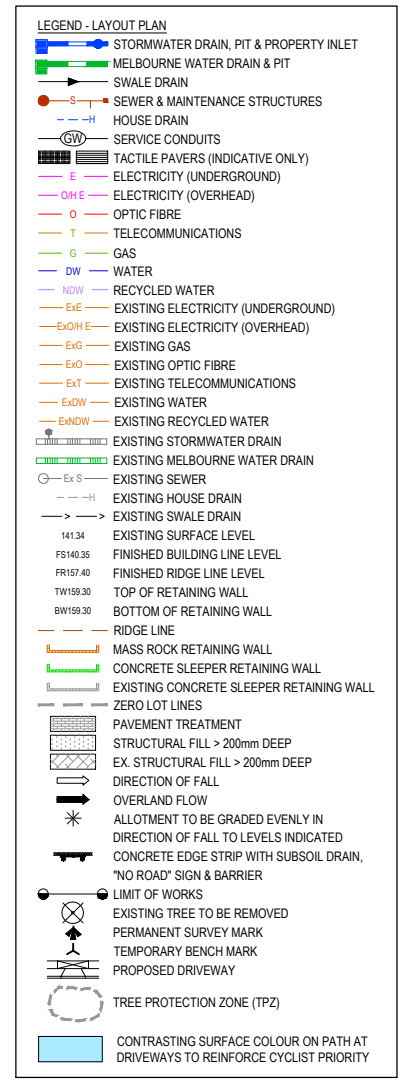

WARNING
BEWARE OF UNDERGROUND SERVICES
 The locations of underground services are approximate only and their exact position should be proven on site.
 No guarantee is given that all existing services are shown. Locate all underground services before commencement of works.
DIAL 1100 BEFORE YOU DIG
 www.1100.com.au

ROAD LAYOUT TABLE

Road Name	Reserve Width (m)	Road Width (m)			Kerb Type		Verge Width (m)	
		Lip to Lip	Inv to Inv	Back to Back	Nth/West	Sth/East	Nth/West	Sth/East
CHITAGON DRIVE	16.00	6.40	7.30	7.60	600 B2	600 B2	4.50	4.20
PORTOBELLO BOULEVARD	20.00	5.10 / 9.70	6.00 / 10.60	6.30 / 7.60	600 B2	600 B2	4.70 / 7.00	4.70 / 7.00
GINN STREET	16.00	6.40	7.30	7.60	600 B2	600 B2	4.20	4.50
BURLINA BOULEVARD	25.50	6.10 / 10.30	7.00 / 11.20	7.30 / 11.50	600 B2	600 B2	4.50 / 6.60	9.80 / 11.90

SERVICE OFFSET TABLE

Location	Side	Gas		ND - Water		Water		Electricity		Telecommunication		Sewer	
		Offset (m)	Side	Offset (m)	Side	Offset (m)	Side	Offset (m)	Side	Offset (m)	Side	Offset (m)	
CHITAGON DRIVE	N	2.10	N	2.50	N	2.95	S	2.30	S	0.80	N	1.00	
PORTOBELLO BOULEVARD	N	2.00	N	2.45	N	2.95	S	2.60	S	1.80	S	1.00	
GINN STREET	E	2.10	E	2.50	E	2.95	W	2.40	W	0.80	-	-	
BURLINA BOULEVARD	E	2.10	E	2.55	E	3.05	W	2.70	W	1.90	-	-	

NOTE: STREET TREES ARE TO BE PLANTED IN THE CENTRE OF ALL NATURE STRIPS

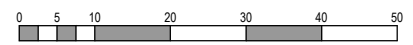

ISSUED FOR CONSTRUCTION

REV	DESCRIPTION	DATE	DRN.	APP.	REV	DESCRIPTION	DATE	DRN.	APP.
B	PRIORITY CROSSING UPDATED	28.03.22	M.F.	M.F.					
A	ISSUED FOR CONSTRUCTION	24.02.22	M.F.	M.F.					



Designed By: E. BARCHAM
 Date: 02.08.2021
 Drawn By: N. TABUENA
 Approved By: M. FELICIANO
 Date: 02.08.2021
 PS Number: PS848726W



Project Details: MERIDIAN CENTRAL ESTATE
 STAGE 31
 CITY OF CASEY
 Drawing Title: LAYOUT PLAN (SHEET 1 OF 2)

Sheet 04 of 27
 Scale: 1:500 @ A1
 Project Ref: 1801767
 Stage No: 31
 Drawing No: 010
 Rev: B

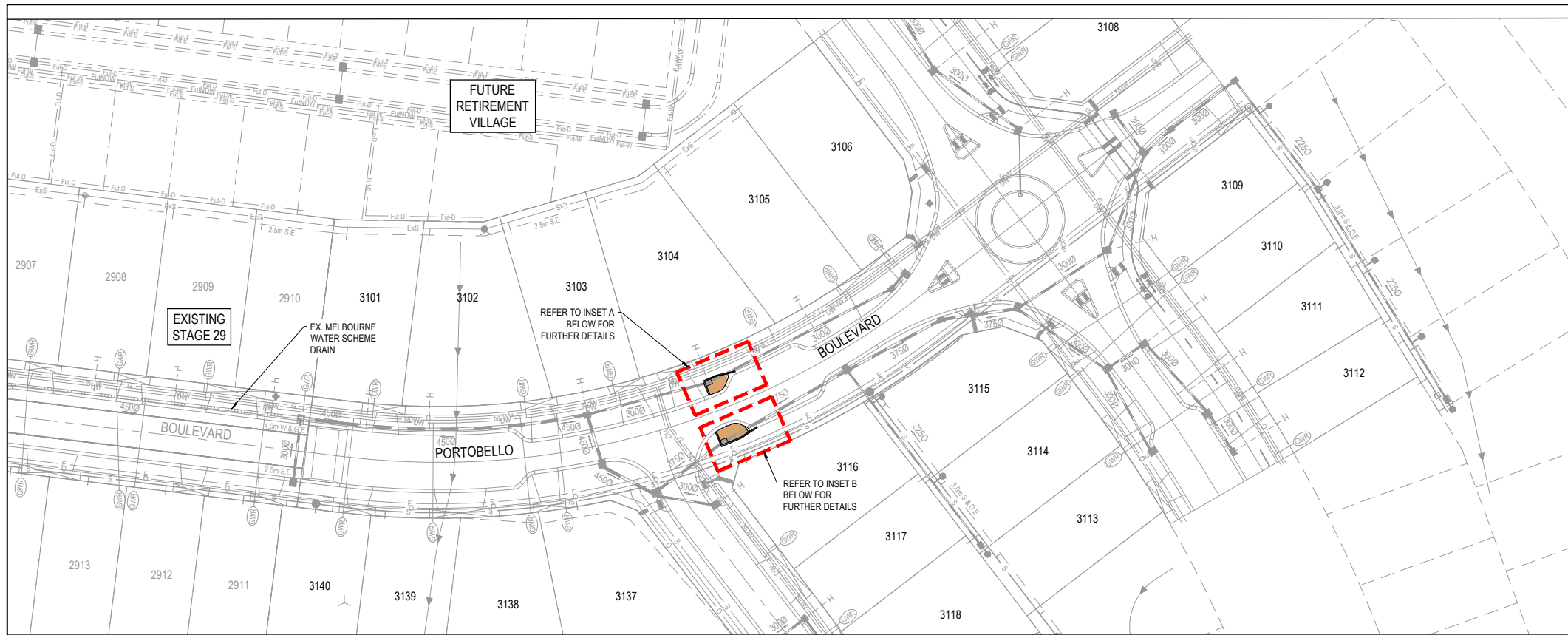

- LEGEND - LAYOUT PLAN**
- STORMWATER DRAIN, PIT & PROPERTY INLET
 - MELBOURNE WATER DRAIN & PIT
 - SWALE DRAIN
 - SEWER & MAINTENANCE STRUCTURES
 - HOUSE DRAIN
 - SERVICE CONDUITS
 - E ELECTRICITY (UNDERGROUND)
 - OH E ELECTRICITY (OVERHEAD)
 - O OPTIC FIBRE
 - T TELECOMMUNICATIONS
 - G GAS
 - DW WATER
 - NDW RECYCLED WATER
 - Ex E EXISTING ELECTRICITY (UNDERGROUND)
 - Ex OH E EXISTING ELECTRICITY (OVERHEAD)
 - Ex G EXISTING GAS
 - Ex O EXISTING OPTIC FIBRE
 - Ex T EXISTING TELECOMMUNICATIONS
 - Ex DW EXISTING WATER
 - Ex NDW EXISTING RECYCLED WATER
 - EXISTING STORMWATER DRAIN
 - EXISTING SEWER
 - EXISTING HOUSE DRAIN
 - EXISTING SWALE DRAIN
 - MASS ROCK RETAINING WALL
 - CONCRETE SLEEPER RETAINING WALL
 - LIMIT OF WORKS
 - EXISTING TREE TO BE REMOVED
 - PROPOSED DRIVEWAY
 - RAINGARDEN
 - 1000 SLOPPED PVC PIPE

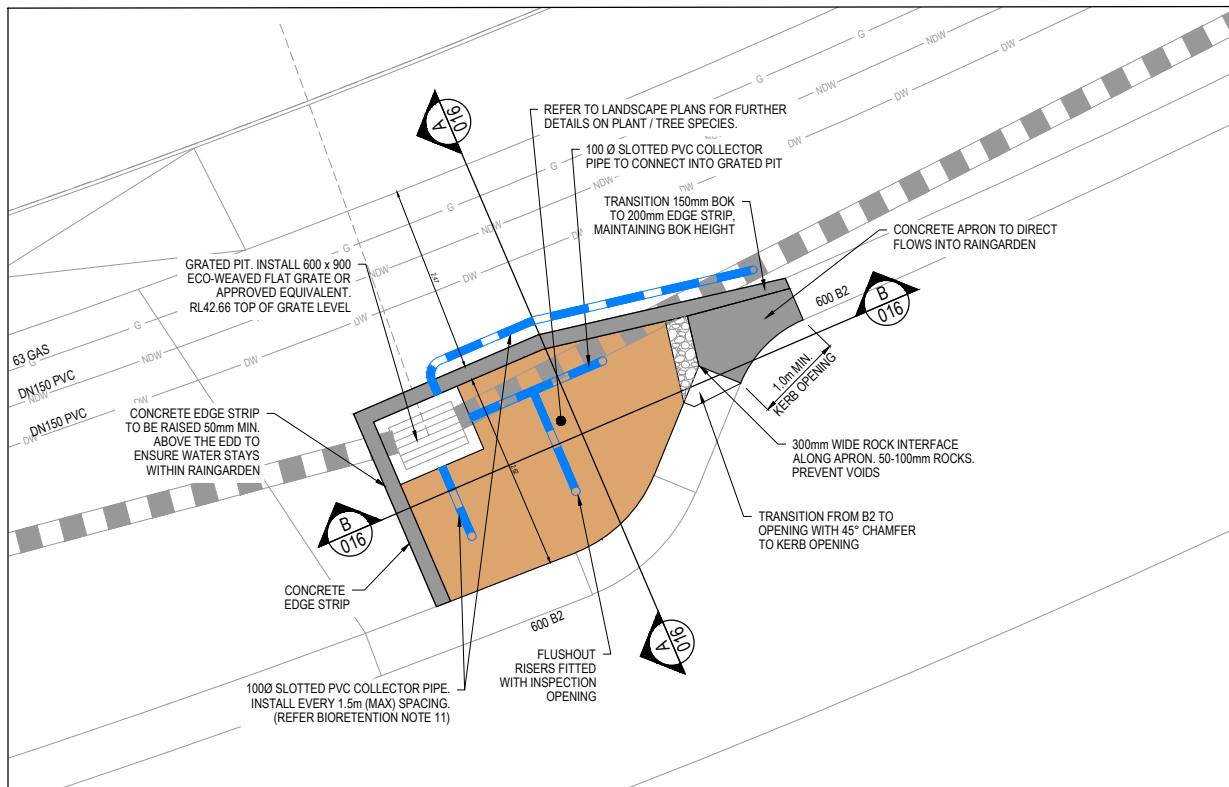
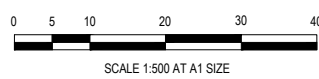

INSET A
SCALE 1:50 AT A1 SIZE

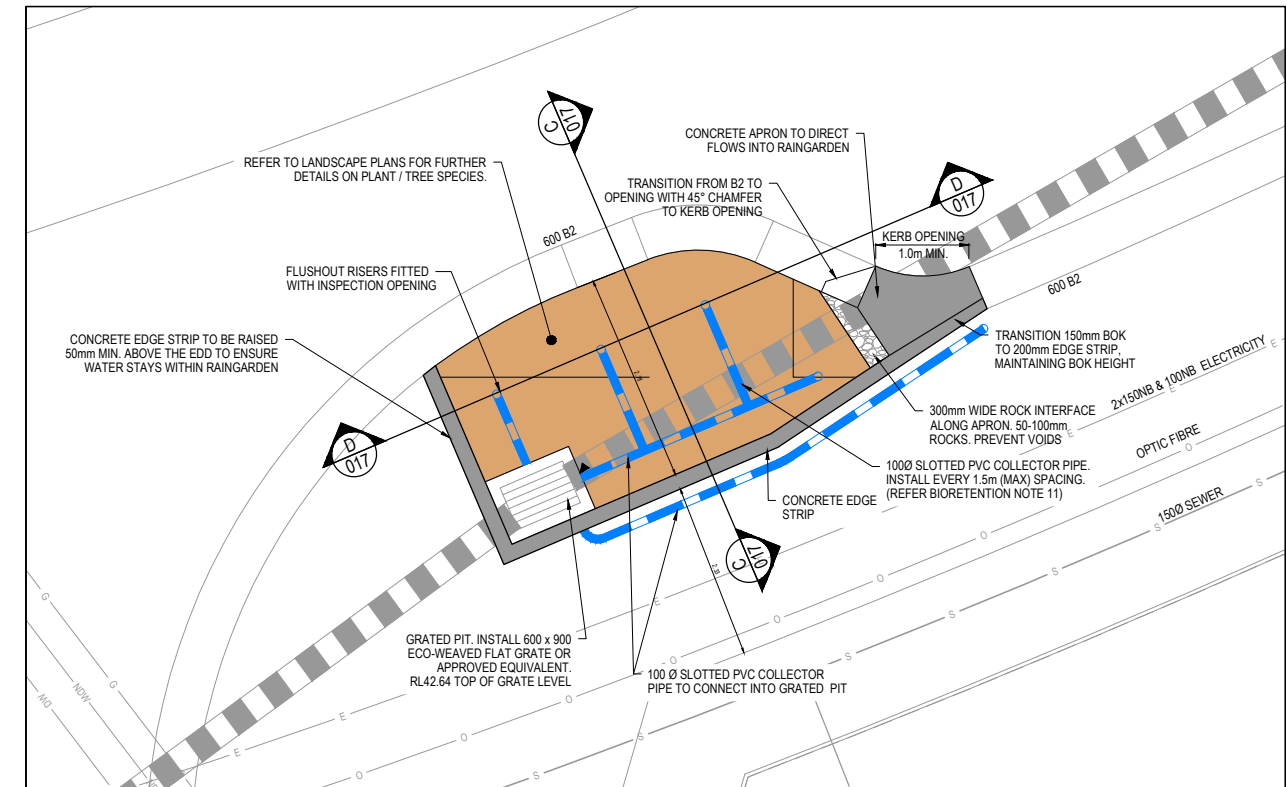

INSET B
SCALE 1:50 AT A1 SIZE

ISSUED FOR CONSTRUCTION

© COPYRIGHT All rights reserved Beveridge Williams & Co. Pty Ltd has granted a licence to the principle to use this document for its intended purpose. No unauthorised copying is permitted					
REV	DESCRIPTION	DATE	DRN.	APP.	REV.
A	ISSUED FOR CONSTRUCTION	24.02.22	M.F.	M.F.	

REV	DESCRIPTION	DATE	DRN.	APP.	REV.	DESCRIPTION	DATE	DRN.	APP.



Designed Date
E. BARCHAM
02.08.2021

Drawn
N. TABUENA

Approved Date
M. FELICIANO
02.08.2021

PS Number
PS84826W



Project Details
MERIDIAN CENTRAL ESTATE
STAGE 31
CITY OF CASEY

Drawing Title
INTEGRATED WATER MANAGEMENT
LAYOUT PLAN

Sheet 06 of 27			
Scale	Project Ref	Stage No	Drawing No
	1801767	31	015
			Rev
			A



K:\Jobs Data\1801767 - Meridian_Eng\Stage 31\Drawings\1801767-31-015-IWMS.dwg

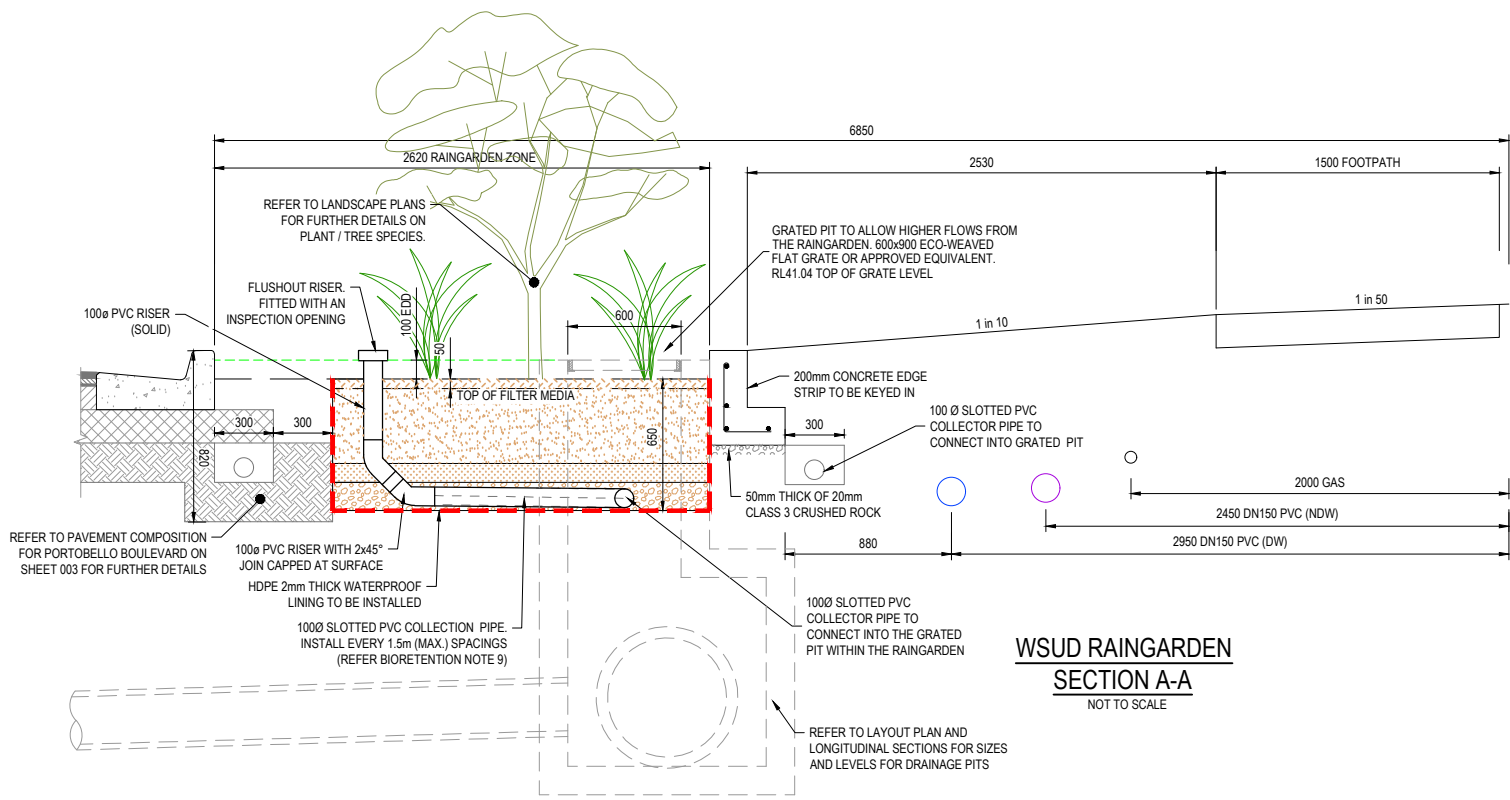

WSUD RAINGARDEN SECTION A-A
NOT TO SCALE

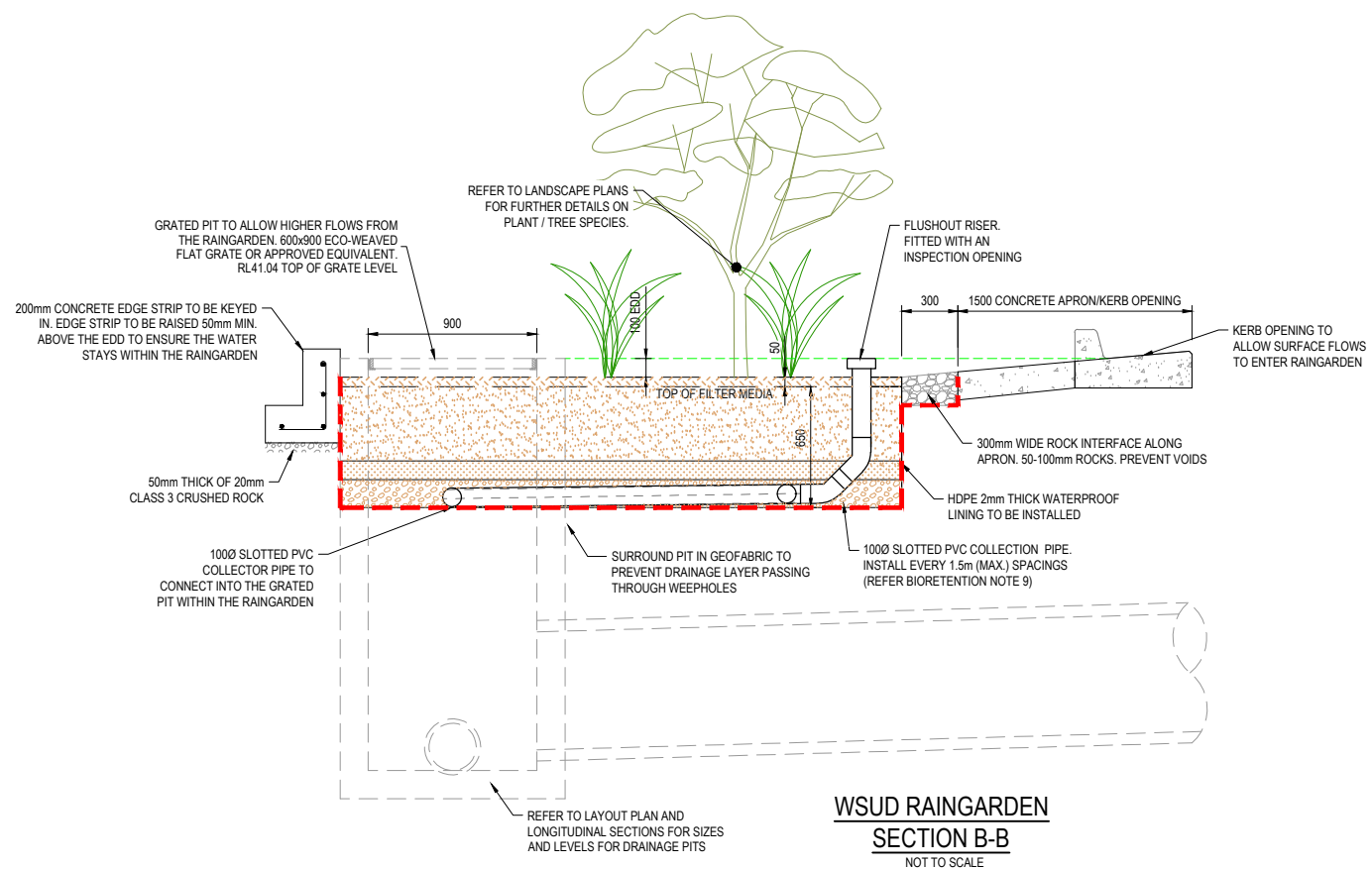

WSUD RAINGARDEN SECTION B-B
NOT TO SCALE

BIORETENTION NOTES

The Bioretention system will operate so that water will infiltrate into the filter media and move vertically through the profile. The Bioretention system requires three layers of media:

1. Filter
2. Transition
3. Drainage

1. FILTER LAYER

600mm depth of material meeting the specifications outlined in CRC for Water Sensitive Cities 'Adoption Guidelines for Stormwater Biofiltration Systems' (July 2015), Appendix C, Table 1.

- Filter media must meet the following specifications:
- a. Material - to be either a washed, well-graded sand, or naturally occurring sand meeting the required specifications.
 - b. Hydraulic Conductivity - 100-300mm/hr
 - c. Clay & Silt Content - < 3% (w/w)
 - d. Smooth Grading - all particle sizes represented across sieve sizes; see also particle size distribution below.
 - e. Nutrient Content - low nutrient content with Total Nitrogen (TN) < 1000 mg/kg, and available phosphate (Colwell) < 80 mg/kg
 - f. Organic Matter Content - minimum content ≤ 5% to support vegetation
 - g. pH - 5.5-7.5, as specified for 'natural soils and soil blends' in AS4419 - 2003 (pH 1.5 in water)
 - h. Electrical conductivity < 1.2 dS/m, as specified for 'natural soils and soil blends' in AS4419 - 2003
 - i. Horticultural suitability - media must be capable of supporting healthy vegetation

Particle Size Distribution of selected filter media to be as follows:

(% w/w)	Retained
Clay & Silt	<3% (<0.05 mm)
Very Fine Sand	5-30% (0.05-0.15 mm)
Fine Sand	10-30% (0.15-0.25 mm)
Medium Sand	40-60% (0.25-0.5 mm)
Coarse Sand	7-10% (0.5-1.0 mm)
Very Coarse Sand	0-10% (1.0-2.0mm)
Fine Gravel	<3% (2.0-3.4 mm)

The Filter media should contain some organic matter for increased water holding capacity but be low in nutrient content. Also the media should be free of rubbish, deleterious material, toxicants and local weeds (as listed in local guidelines/ acts) and should not be hydrophobic.

2. TRANSITION LAYER

100mm depth of material meeting the specifications outlined in CRC for Water Sensitive Cities 'Adoption Guidelines for Stormwater Biofiltration Systems' (July 2015), Appendix C, Table 1.

- Transition layer material must meet the following specifications:
- a. Material - to be a clean, well-graded sand
 - b. Hydraulic Conductivity - must be higher than the hydraulic conductivity of the overlying filter media
 - c. Fine Particle Content - < 2%

Particle Size Distribution of the selected transition layer material must meet bridging criteria, the smallest 15% of sand particles must bridge with the largest 15% of filter media particles:

$D_{15} \text{ (transition layer)} \leq 5 \times D_{85} \text{ (filter media)}$

3. DRAINAGE LAYER

150mm depth of material meeting the specifications outlined in CRC for Water Sensitive Cities 'Adoption Guidelines for Stormwater Biofiltration Systems' (July 2015), Appendix C, Table 1.

- Transition layer material must meet the following specifications:
- a. Material - to be clean, fine aggregate, 2-7mm washed screenings (not scoria or quartz)
 - b. Hydraulic Conductivity - must be higher than the hydraulic conductivity of the overlying transition layer

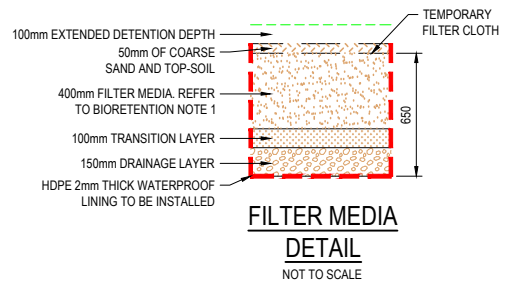

Particle Size Distribution of the selected drainage layer material must meet bridging criteria; the smallest 15% of drainage layer particles must bridge with the largest 15% of transition layer particles:

$D_{15} \text{ (drainage layer)} \leq 5 \times D_{85} \text{ (transition layer)}$

Perforations in subsoil drainage must be small enough relative to the drainage layer material.

$D_{85} \text{ (drainage layer)} > \text{diameter subsoil drain pipe perforation}$

4. TEMPORARY FILTER LAYER

A layer of 75mm topsoil preferred / 50mm stone aggregate of 5-13mm, no fines

5. TESTING REQUIREMENTS

Testing to confirm Hydraulic Conductivity of the media under various levels of compaction shall be conducted using the ASTM F1815-06 Method.

Test imported topsoils and submit test results for approval at least 5 working days in advance of carting. In addition, the contractor is to supply a 500 gram sample of the filter medium to the superintendent for approval prior to purchasing bulk material.

The following tests are to be conducted to determine the suitability of selected media. The test results are to be submitted to the superintendent with Hydraulic Conductivity results for approval before placing bulk orders:

- Particle Size Distribution (PSD)
- AS4419-2003 - Soil properties for landscaping and garden use - Sandy Loam
- Saturated Hydraulic Conductivity
- Water holding capacity, where PSD does not meet specifications but silt and clay is <12%
- PH

Where a supplier can provide PSD and/or AS4419-2003 test results for the specific batch of media being purchased these will be accepted at the superintendents discretion.

6. INSTALLATION

Filter media shall be lightly compacted during installation to prevent migration of fine particles.

A single pass with a vibrating plate or roller machinery(e.g. a drum lawn roller) should be used to compact the filter media. Under no circumstances should heavy compaction or multiple passes be made. Filter media is to be installed near the completion of works to ensure the media quality is not affected due to ongoing construction works.

7. MAINTENANCE

Field testing of hydraulic Conductivity shall be carried out at three points within the system at one month following commencement of operation and in the second year of operation to assess the impact of vegetation on Hydraulic Conductivity. Weed management will need to be done manually until such time that the design vegetation is established with sufficient density to effectively prevent weed propagation.

8. TEMPORARY FILTER CLOTH

Surface of Filtration media to be covered with a temporary filter cloth (Bidim or Similar). Temporary Filter cloth to be removed and planting of the Bioretention Basin undertaken in accordance with the landscape plans once the building phase within the catchment is 80 - 90% complete.

9. COLLECTION (AG) PIPES

Collection pipes to be 100 dia. PVC SN6 (i.e. Sewer Grade), slotted with 2mm width slots. Minimum slot length = 1.2m of slot per lineal metre of pipe. Slotting can be undertaken by Central Pipe Fabrication or similar companies.

WARNING
BWARE OF UNDERGROUND SERVICES

The locations of underground services are approximate only and their exact position should be proven on site. No guarantee is given that all existing services are shown. Locate all underground services before commencement of works

DIAL 1100 BEFORE YOU DIG
www.1100.com.au

ISSUED FOR CONSTRUCTION

© COPYRIGHT All rights reserved
Beveridge Williams & Co. Pty Ltd has granted a licence to the principle to use this document for its intended purpose.
No unauthorised copying is permitted

REV	DESCRIPTION	DATE	DRN.	APP.	REV	DESCRIPTION	DATE	DRN.	APP.
A	ISSUED FOR CONSTRUCTION	24.02.22	M.F	M.F					



Designed Date: E. BARCHAM 02.08.2021
Drawn: N. TABUENA
Approved Date: M. FELICIANO 02.08.2021
PS Number: PS848726W



Project Details: MERIDIAN CENTRAL ESTATE
STAGE 31
CITY OF CASEY
Drawing Title: INTEGRATED WATER MANAGEMENT
DETAILS (SHEET 1 OF 2)

Sheet 07 of 27

Project Ref	Stage No	Drawing No	Rev
1801767	31	016	A

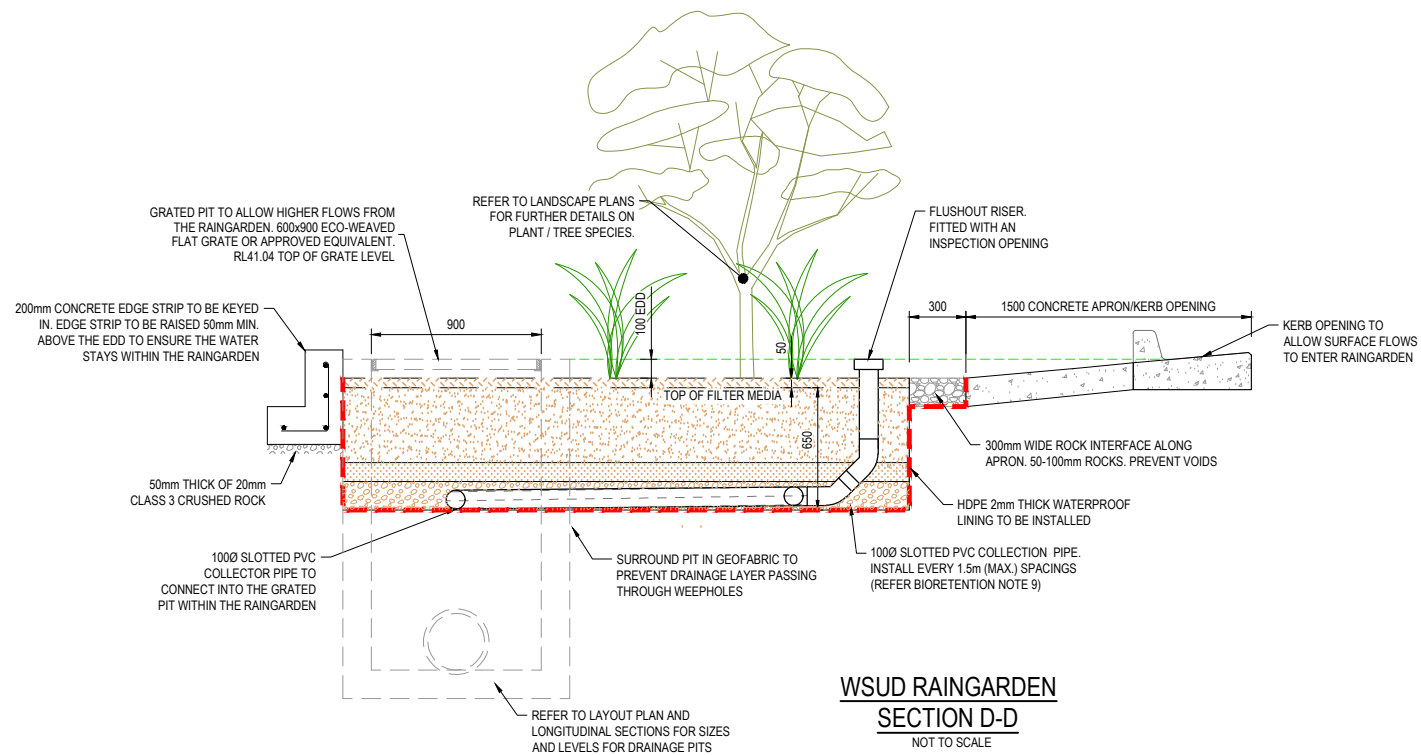
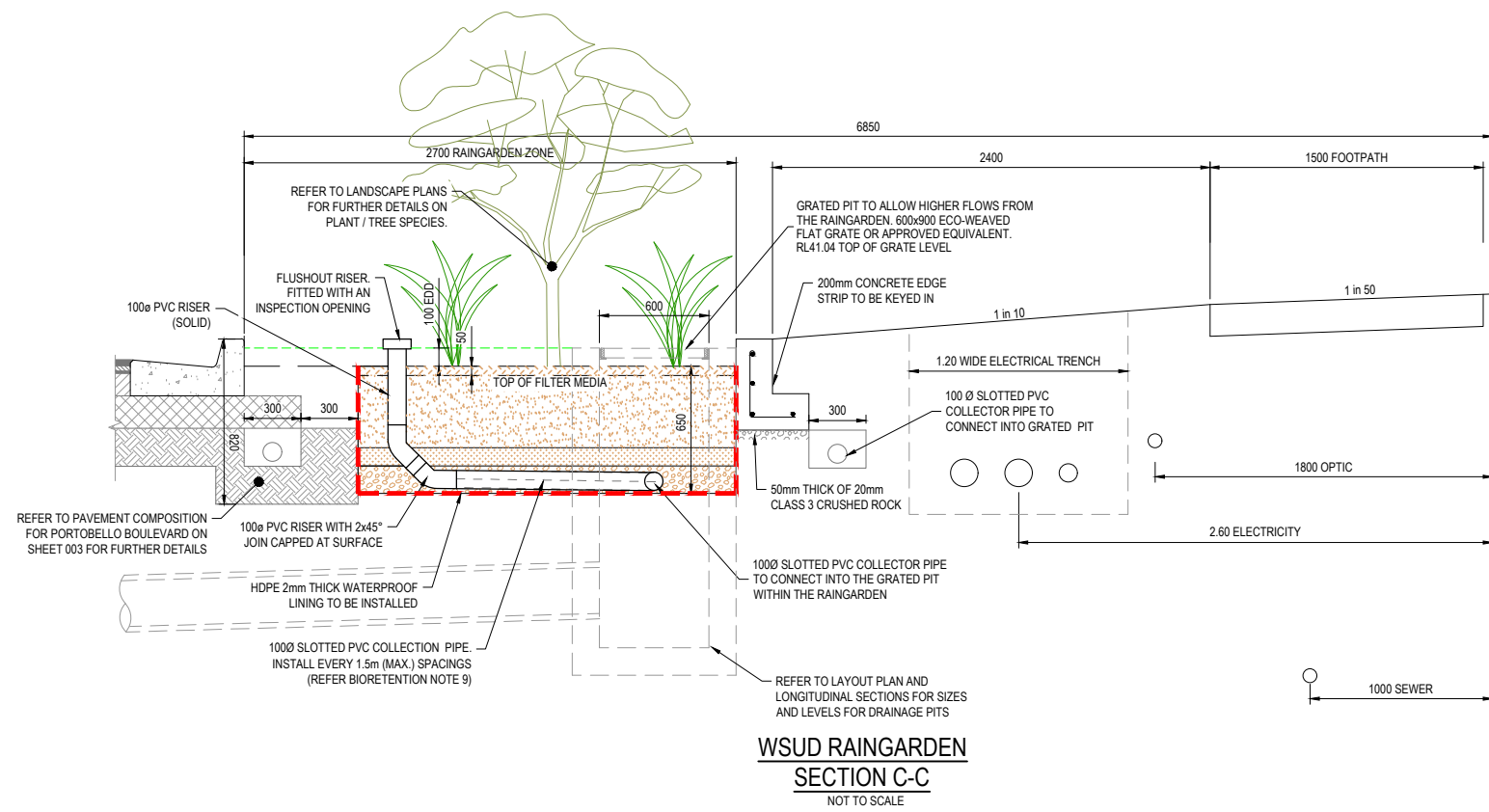

WARNING
Beware of Underground Services
 The locations of underground services are approximate only and their exact position should be proven on site.
 No guarantee is given that all existing services are shown. Locate all underground services before commencement of works.
DIAL 1100 BEFORE YOU DIG
 www.1100.com.au

ISSUED FOR CONSTRUCTION

© COPYRIGHT All rights reserved Beveridge Williams & Co. Pty Ltd has granted a licence to the principle to use this document for its intended purpose. No unauthorised copying is permitted									
A	ISSUED FOR CONSTRUCTION	24.02.22	M.F	M.F					
REV	DESCRIPTION	DATE	DRN.	APP.	REV	DESCRIPTION	DATE	DRN.	APP.



Designed Date: E. BARCHAM 02.08.2021
 Drawn: N. TABUENA
 Approved Date: M. FELICIANO 02.08.2021
 PS Number: PS84826W



Project Details: MERIDIAN CENTRAL ESTATE STAGE 31 CITY OF CASEY
 Drawing Title: INTEGRATED WATER MANAGEMENT DETAILS (SHEET 2 OF 2)

Sheet 08 of 27			
Scale			
Project Ref	Stage No	Drawing No	Rev
1801767	31	017	A



LEGEND	
	EXISTING SURFACE
	DESIGN LINE
	FUTURE DESIGN LINE
	EXISTING SURFACE AT SOUTH / WEST BOUNDARY
	SOUTH / WEST LIP OF KERB
	EXISTING SURFACE AT NORTH / EAST BOUNDARY
	NORTH / EAST LIP OF KERB

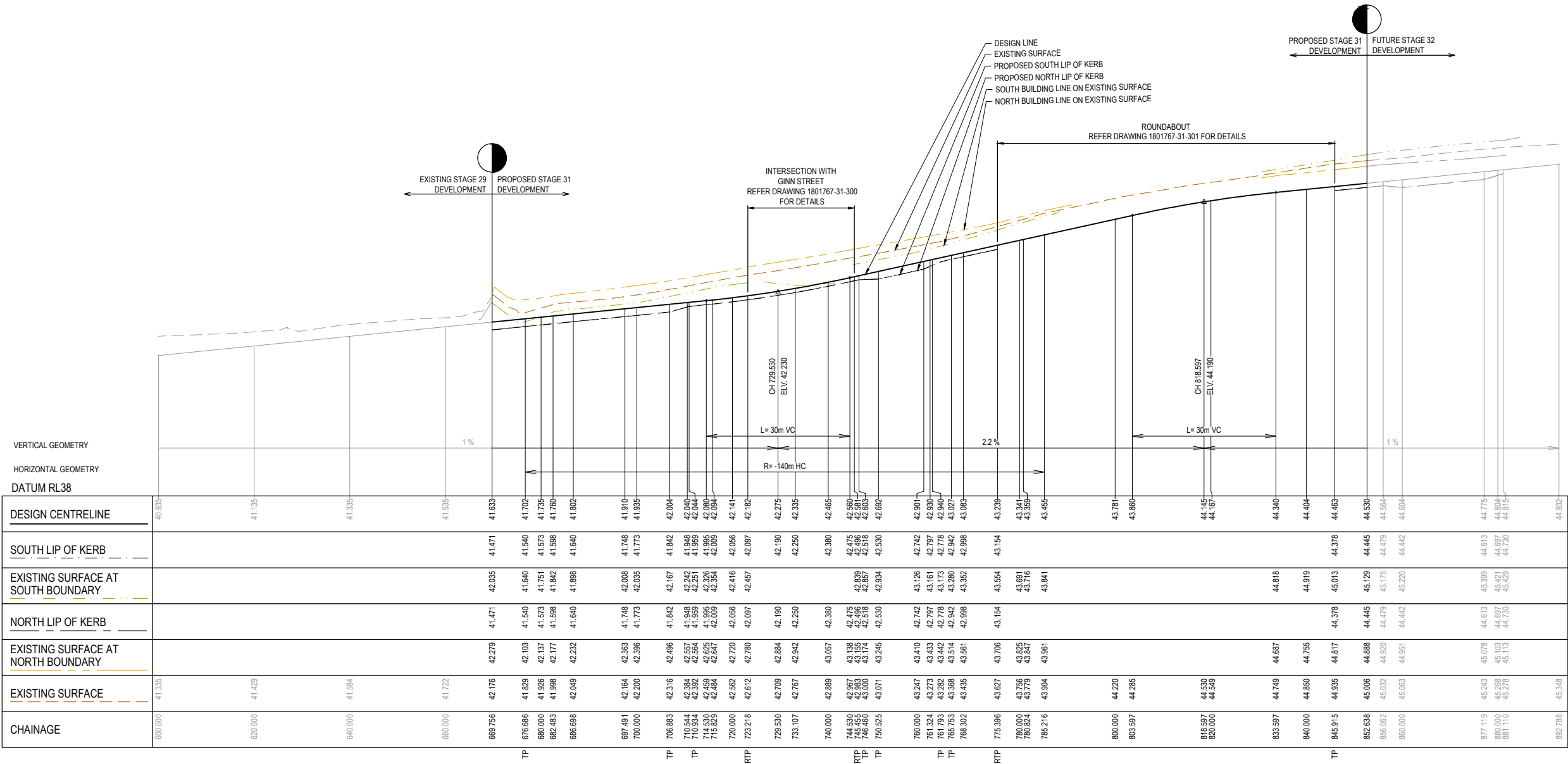

VERTICAL GEOMETRY
HORIZONTAL GEOMETRY
DATUM RL38

DESIGN CENTRELINE	40.935	41.135	41.335	41.535	41.633	41.702	41.735	41.760	41.802	41.910	41.935	42.004	42.040	42.044	42.080	42.094	42.141	42.182	42.275	42.335	42.465	42.560	42.581	42.603	42.692	42.901	42.930	42.940	43.027	43.083	43.239	43.341	43.359	43.455	43.781	43.860	44.145	44.167	44.340	44.404	44.463	44.530	44.564	44.604	44.775	44.775	44.804	44.815	44.832	
SOUTH LIP OF KERB					41.471	41.540	41.573	41.598	41.640	41.748	41.773	41.842	41.840	41.948	41.959	41.995	42.009	42.056	42.097	42.190	42.250	42.380	42.475	42.486	42.518	42.530	42.742	42.797	42.778	42.842	42.898	43.154	43.341	43.359	43.455	43.781	43.860	44.145	44.167	44.340	44.404	44.463	44.530	44.564	44.604	44.775	44.775	44.804	44.815	44.832
EXISTING SURFACE AT SOUTH BOUNDARY					42.035	41.640	41.573	41.598	41.640	41.748	42.035	41.842	41.840	41.948	41.959	41.995	42.009	42.056	42.097	42.190	42.250	42.380	42.475	42.486	42.518	42.530	42.742	42.797	42.778	42.842	42.898	43.154	43.341	43.359	43.455	43.781	43.860	44.145	44.167	44.340	44.404	44.463	44.530	44.564	44.604	44.775	44.775	44.804	44.815	44.832
NORTH LIP OF KERB					41.471	41.540	41.573	41.598	41.640	41.748	41.773	41.842	41.840	41.948	41.959	41.995	42.009	42.056	42.097	42.190	42.250	42.380	42.475	42.486	42.518	42.530	42.742	42.797	42.778	42.842	42.898	43.154	43.341	43.359	43.455	43.781	43.860	44.145	44.167	44.340	44.404	44.463	44.530	44.564	44.604	44.775	44.775	44.804	44.815	44.832
EXISTING SURFACE AT NORTH BOUNDARY					42.279	42.103	42.137	42.177	42.232	42.363	42.396	42.496	42.496	42.564	42.564	42.625	42.647	42.720	42.780	42.884	42.942	43.057	43.138	43.155	43.174	43.245	43.410	43.433	43.442	43.514	43.561	43.706	43.825	43.847	43.961	43.781	43.860	44.145	44.167	44.340	44.404	44.463	44.530	44.564	44.604	44.775	44.775	44.804	44.815	44.832
EXISTING SURFACE	41.335	41.429	41.584	41.722	42.176	41.829	41.926	41.998	42.049	42.164	42.200	42.316	42.384	42.392	42.459	42.484	42.562	42.612	42.709	42.767	42.889	42.967	42.983	43.000	43.071	43.245	43.410	43.433	43.442	43.514	43.561	43.706	43.825	43.847	43.961	43.781	43.860	44.145	44.167	44.340	44.404	44.463	44.530	44.564	44.604	44.775	44.775	44.804	44.815	44.832
CHAINAGE	600.000	620.000	640.000	660.000	669.756	676.686	680.000	682.483	686.698	697.491	700.000	706.883	710.544	710.934	714.530	715.823	720.000	723.218	729.530	733.107	740.000	744.530	745.455	746.460	750.525	760.000	761.324	761.793	765.753	768.302	775.396	780.000	780.824	785.216	800.000	803.597	818.597	820.000	833.597	840.000	845.915	852.638	856.062	860.000	877.119	880.000	881.110	892.788		

PORTOBELLO BOULEVARD - ROAD LONGITUDINAL SECTION

ISSUED FOR CONSTRUCTION

REV	DESCRIPTION	DATE	DRN.	APP.	REV	DESCRIPTION	DATE	DRN.	APP.
A	ISSUED FOR CONSTRUCTION	24.02.22	M.F.	M.F.					

BROWN PROPERTY GROUP

M MERIDIAN CENTRAL

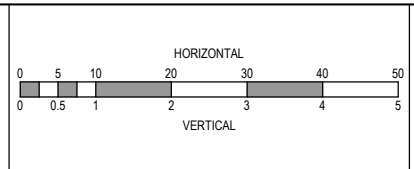

Designed Date: E. BARCHAM 02.08.2021
Drawn: N. TABUENA
Approved Date: M. FELICIANO 02.08.2021
PS Number: PS848726W

BW Beveridge Williams

1 Glenferrie Road
Malvern VIC 3144
ph: 03 9524 8888
www.beveridgewilliams.com.au

Project Details: MERIDIAN CENTRAL ESTATE STAGE 31 CITY OF CASEY
Drawing Title: ROAD LONGITUDINAL SECTIONS PORTOBELLO BOULEVARD

Sheet 09 of 27
Scale: 1:500 H 1:50 V @ A1
Project Ref: 1801767 Stage No: 31 Drawing No: 100 Rev: A

K:\Jobs Data\1801767 - Meridian_Eng\Stage 31\Drawings\1801767-31-100-RLS.dwg

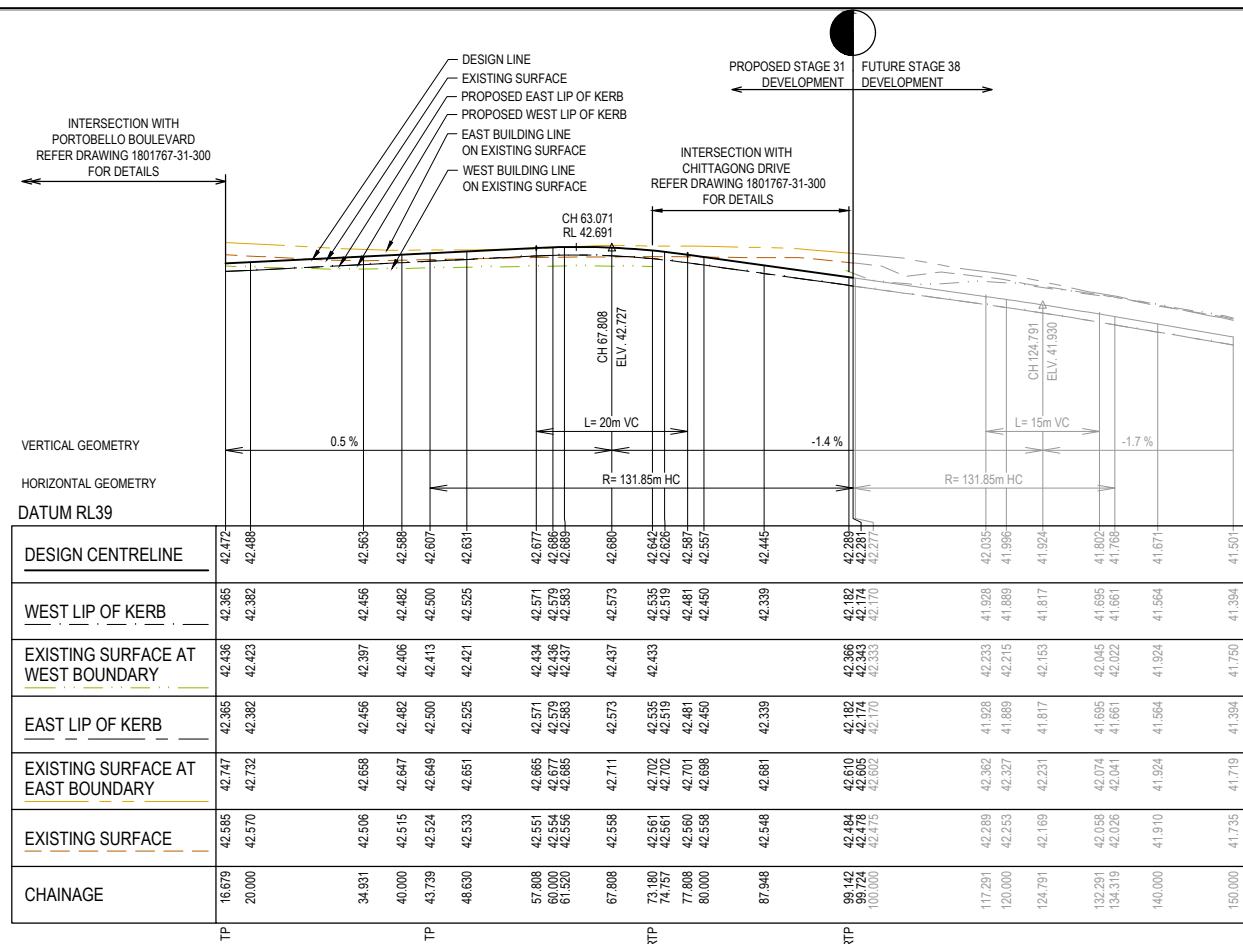

GININ STREET - ROAD LONGITUDINAL SECTION

LEGEND	
	EXISTING SURFACE
	DESIGN LINE
	FUTURE DESIGN LINE
	EXISTING SURFACE AT SOUTH / WEST BOUNDARY
	SOUTH / WEST LIP OF KERB
	EXISTING SURFACE AT NORTH / EAST BOUNDARY
	NORTH / EAST LIP OF KERB

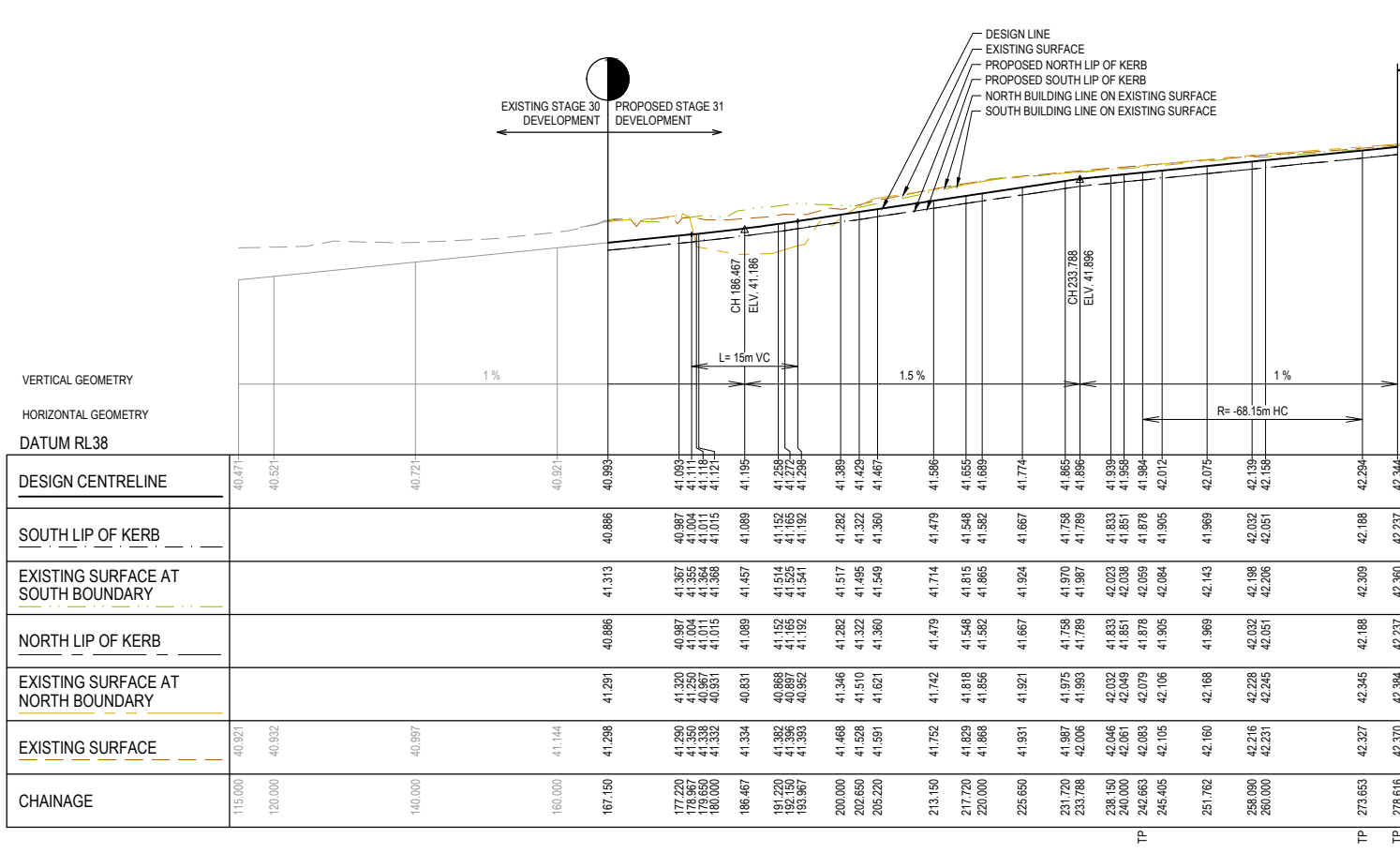

CHITTAGONG DRIVE - ROAD LONGITUDINAL SECTION

ISSUED FOR CONSTRUCTION

REV	DESCRIPTION	DATE	DRN.	APP.	REV	DESCRIPTION	DATE	DRN.	APP.
A	ISSUED FOR CONSTRUCTION	24.02.22	M.F.	M.F.					

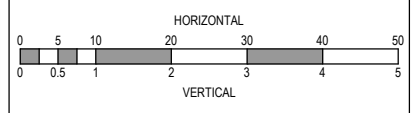

Designed Date: E. BARCHAM 02.08.2021
 Drawn: N. TABUENA
 Approved Date: M. FELICIANO 02.08.2021
 PS Number: PS848726W

BW Beveridge Williams
 1 Glenferrie Road
 Malvern VIC 3144
 ph: 03 9524 8888
 www.beveridgewilliams.com.au

Project Details	MERIDIAN CENTRAL ESTATE STAGE 31 CITY OF CASEY
Drawing Title	ROAD LONGITUDINAL SECTIONS CHITTAGONG DRIVE & GININ STREET

Sheet 11 of 27	Scale: 1:500 H 1:50 V @ A1
Project Ref: 1801767	Stage No: 31
Drawing No: 102	Rev: A

K:\Jobs Data\1801767 - Meridian_Eng\Stage 31\Drawings\1801767-31-100-RLS.dwg

STRUCTURAL FILL REQUIRED UNDER PAVEMENT AND FOOTPATHS WHERE CONSTRUCTED ABOVE NATURAL SURFACE. REFER GEOTECH REPORT FOR SPECIFICATION

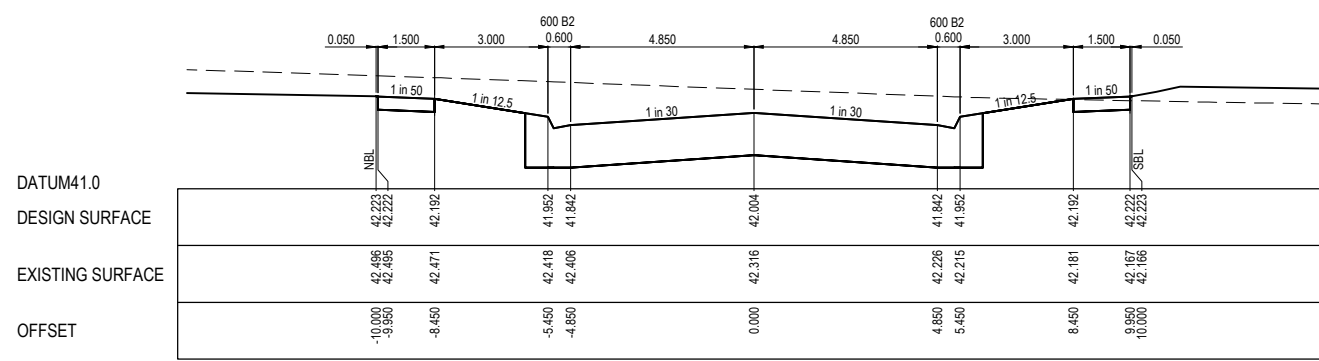
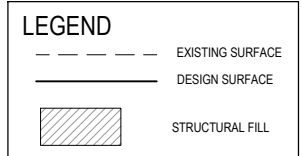

TPCH 706.883

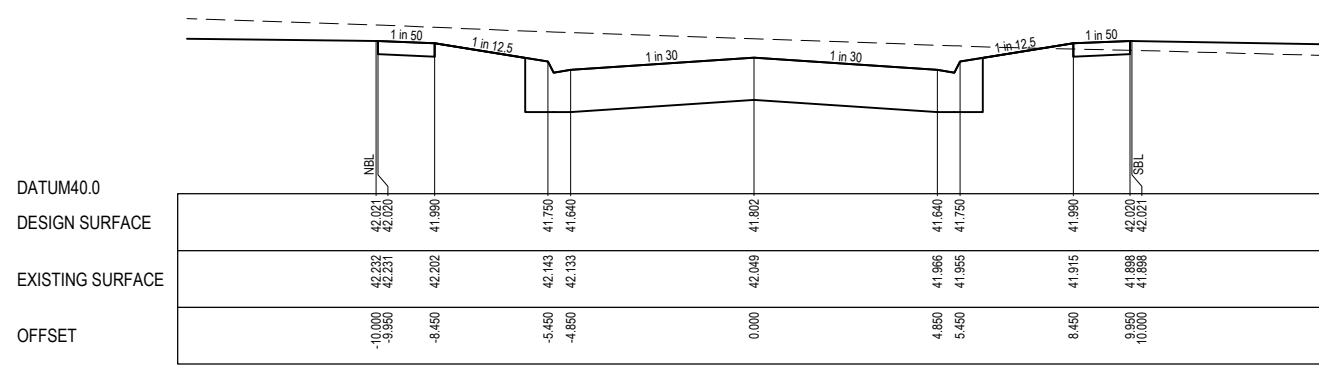

CH 686.698

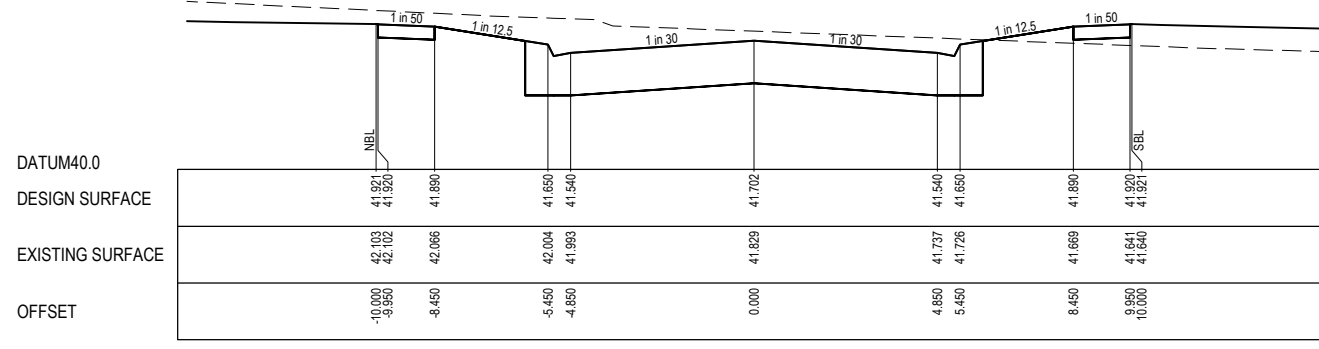

TPCH 676.686

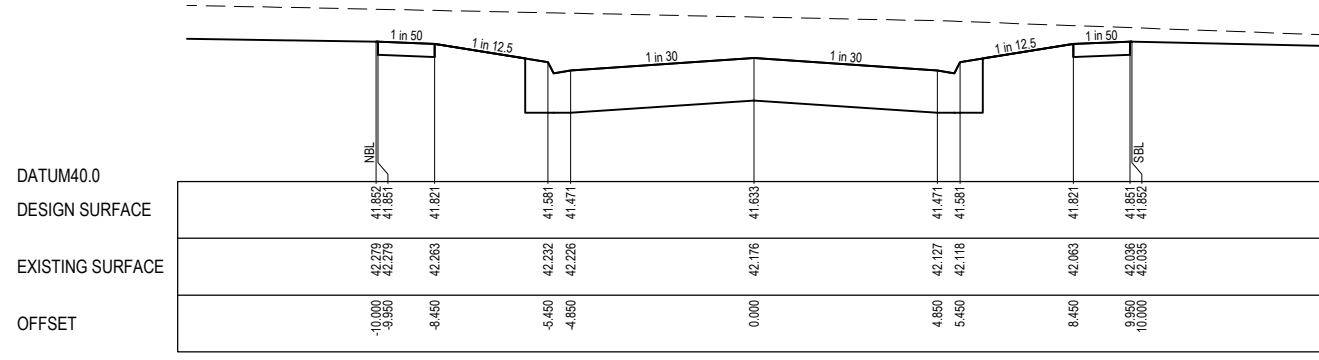

CH 669.756

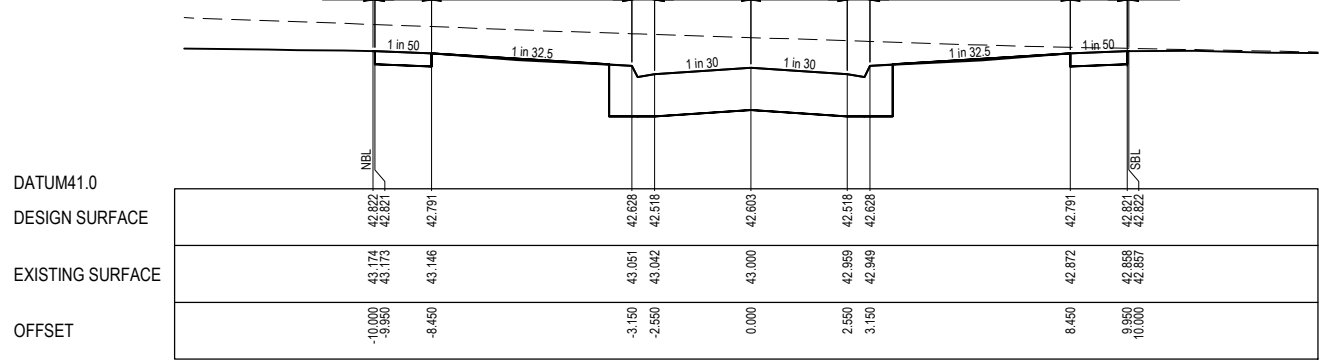

TPCH 746.460

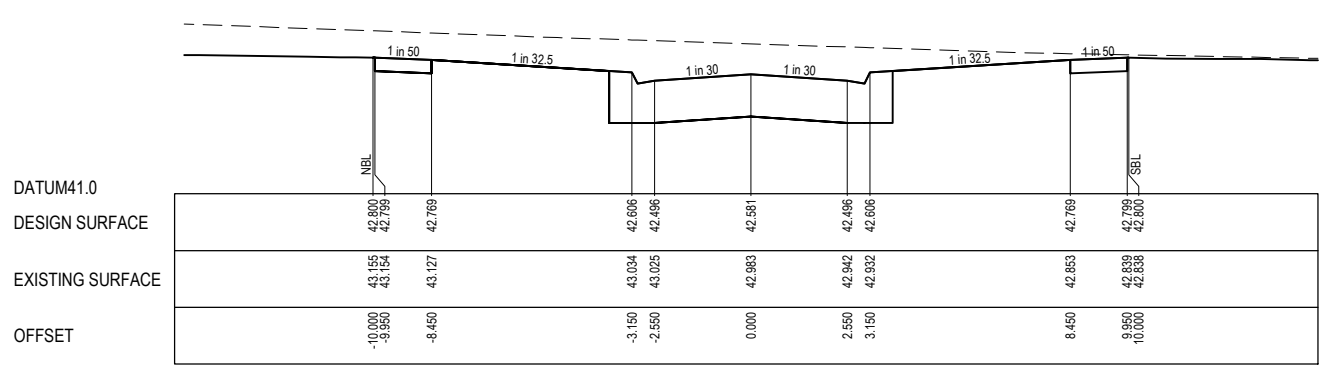

RTPCH 745.455

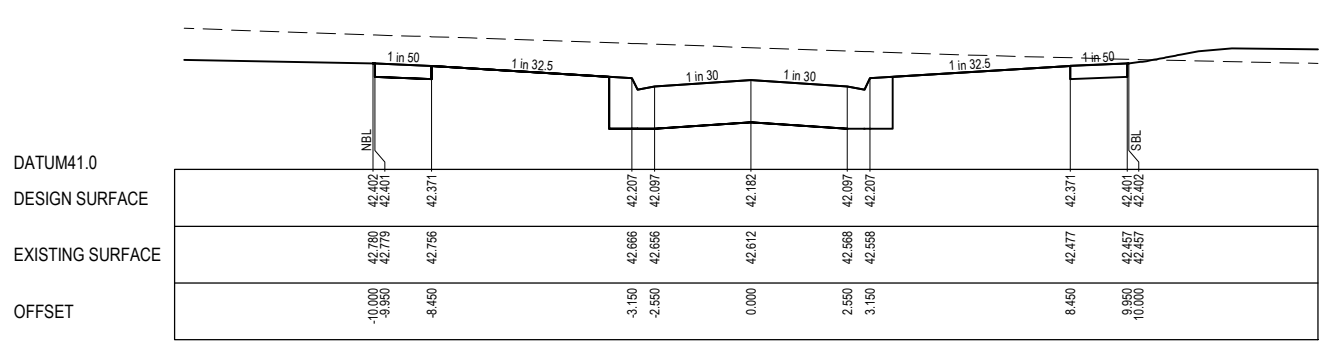

RTPCH 723.218

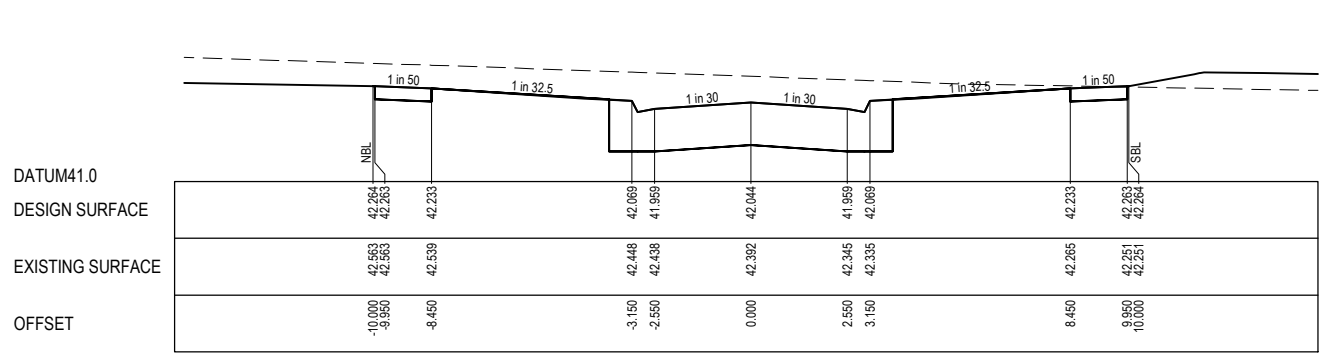

TPCH 710.934

ISSUED FOR CONSTRUCTION

© COPYRIGHT All rights reserved Beveridge Williams & Co. Pty Ltd has granted a licence to the principle to use this document for its intended purpose. No unauthorised copying is permitted.									
REV	DESCRIPTION	DATE	DRN.	APP.	REV	DESCRIPTION	DATE	DRN.	APP.
A	ISSUED FOR CONSTRUCTION	24.02.22	M.F	M.F					

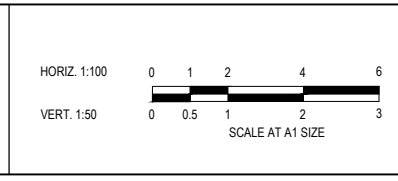

Designed Date: E. BARCHAM 02.08.2021
Drawn: N. TABUENA
Approved Date: M. FELICIANO 02.08.2021
PS Number: PS848726W



Project Details: MERIDIAN CENTRAL ESTATE STAGE 31 CITY OF CASEY
Drawing Title: ROAD CROSS SECTIONS PORTOBELLO BOULEVARD (SHEET 1 OF 2)

Sheet 12 of 27
Scale: 1:100 H 1:50 V @ A1
Project Ref: 1801767 Stage No: 31 Drawing No: 200 Rev: A

K:\Jobs Data\1801767 - Meridian_Eng\Stage 31\Drawings\1801767-31-200-RXS.dwg

STRUCTURAL FILL REQUIRED UNDER PAVEMENT AND FOOTPATHS WHERE CONSTRUCTED ABOVE NATURAL SURFACE. REFER GEOTECH REPORT FOR SPECIFICATION

LEGEND

- EXISTING SURFACE
- DESIGN SURFACE
- ▨ STRUCTURAL FILL

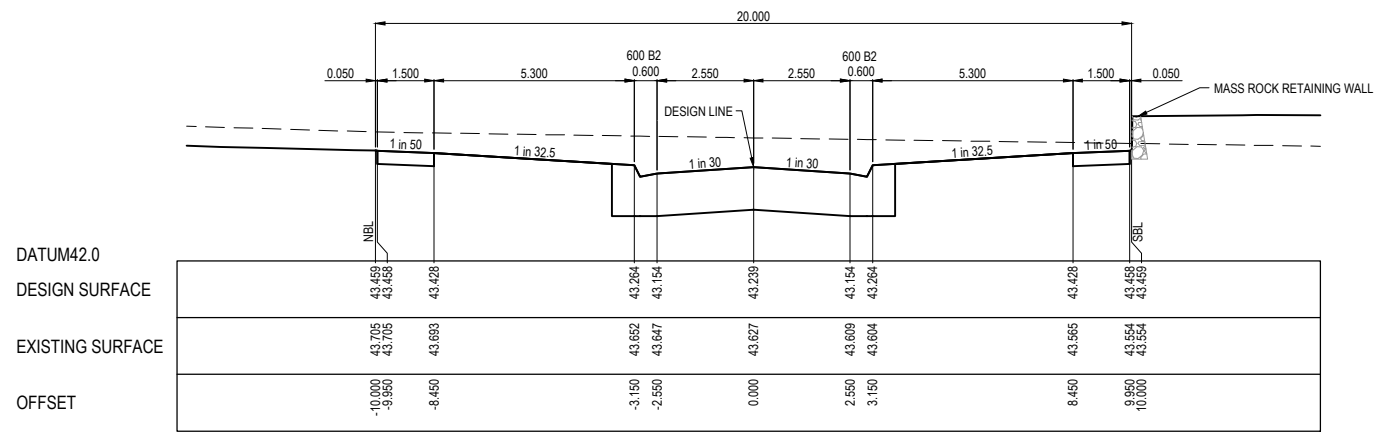

TPCH 775.396

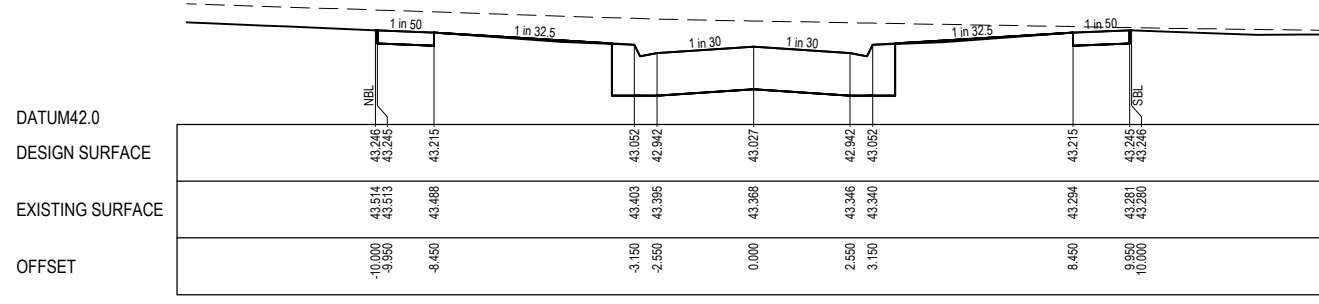

TPCH 765.753

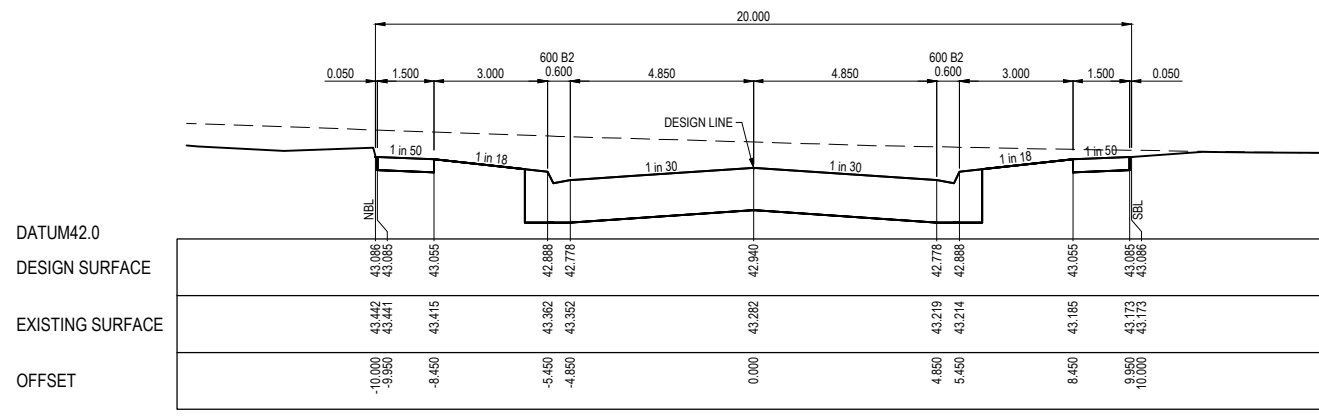

TPCH 761.793

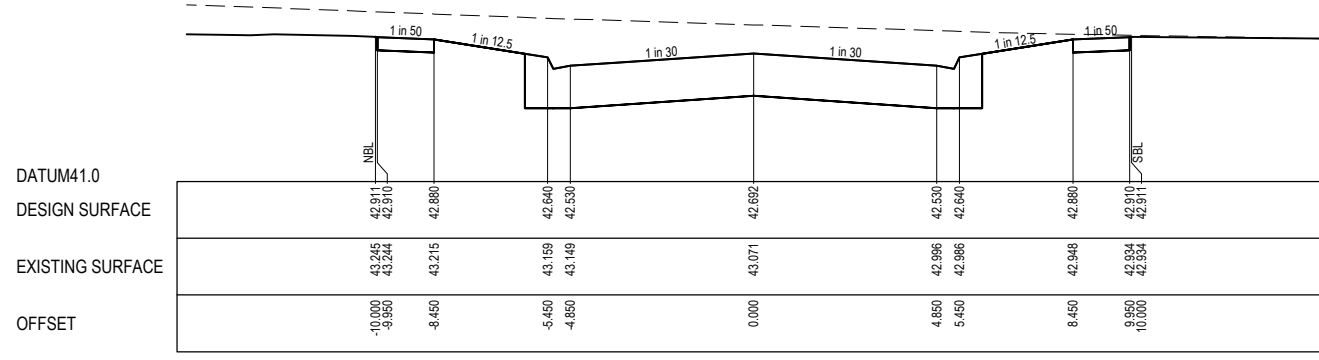

TPCH 750.525

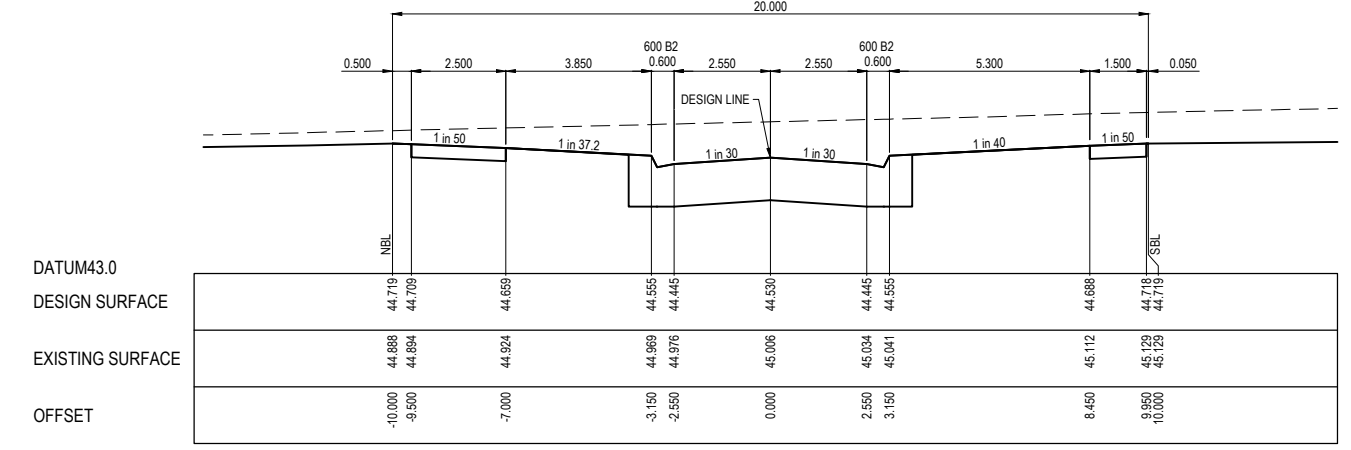

CH 852.638

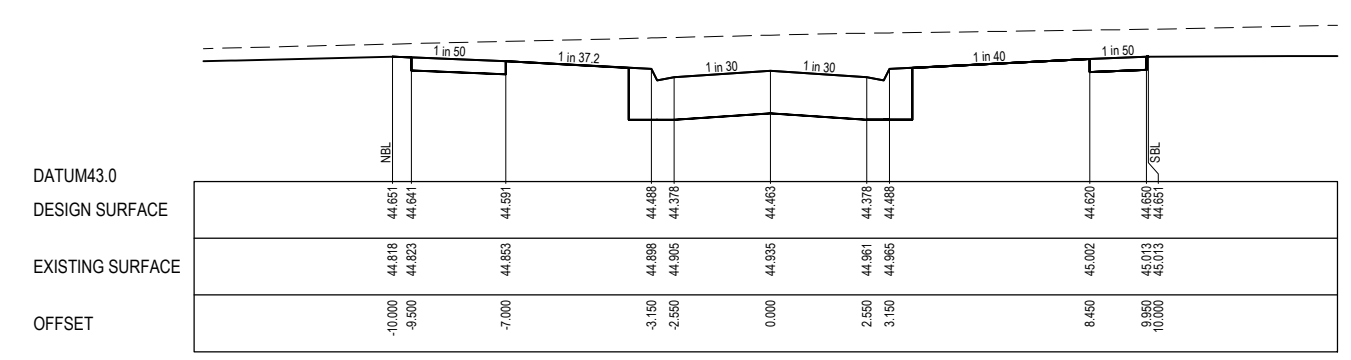

TPCH 845.916

ISSUED FOR CONSTRUCTION

© COPYRIGHT All rights reserved
Beveridge Williams & Co. Pty Ltd has granted a licence to the principle to use this document for its intended purpose.
No unauthorised copying is permitted

REV	DESCRIPTION	DATE	DRN.	APP.	REV	DESCRIPTION	DATE	DRN.	APP.
A	ISSUED FOR CONSTRUCTION	24.02.22	M.F.	M.F.					

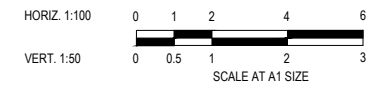

Designed Date: E. BARCHAM 02.08.2021
Drawn: N. TABUENA
Approved Date: M. FELICIANO 02.08.2021
PS Number: PS848726W



Project Details: MERIDIAN CENTRAL ESTATE
STAGE 31
CITY OF CASEY
Drawing Title: ROAD CROSS SECTIONS
PORTOBELLO BOULEVARD
(SHEET 2 OF 2)

Sheet 13 of 27
Scale: 1:100 H 1:50 V @ A1
Project Ref: 1801767
Stage No: 31
Drawing No: 201
Rev: A

K:\Jobs Data\1801767 - Meridian_Eng\Stage 31\Drawings\1801767-31-200-RXS.dwg

STRUCTURAL FILL REQUIRED UNDER PAVEMENT AND FOOTPATHS WHERE CONSTRUCTED ABOVE NATURAL SURFACE. REFER GEOTECH REPORT FOR SPECIFICATION

LEGEND

- EXISTING SURFACE
- DESIGN SURFACE
- STRUCTURAL FILL

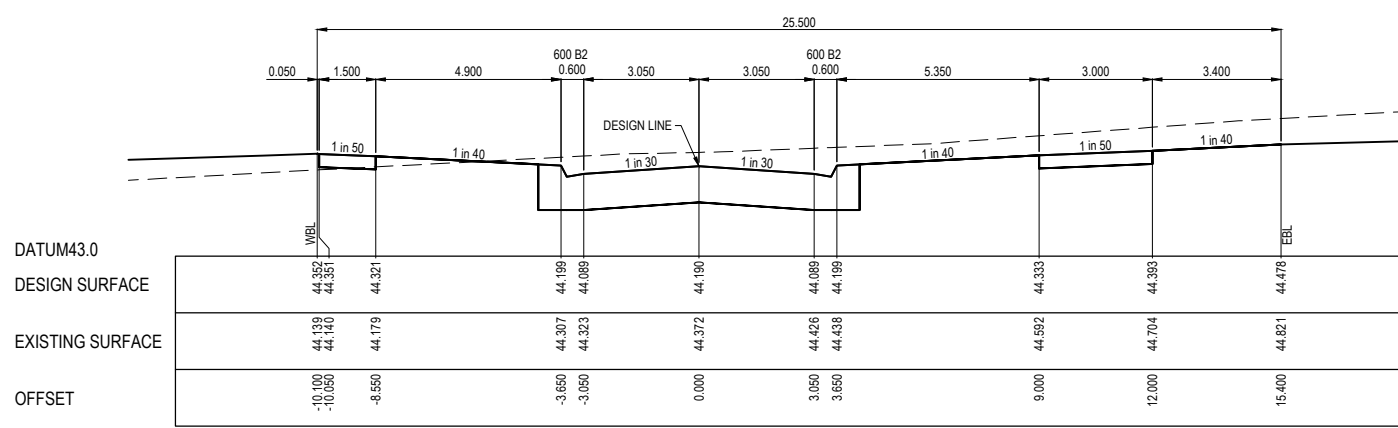

TPCH 268.112

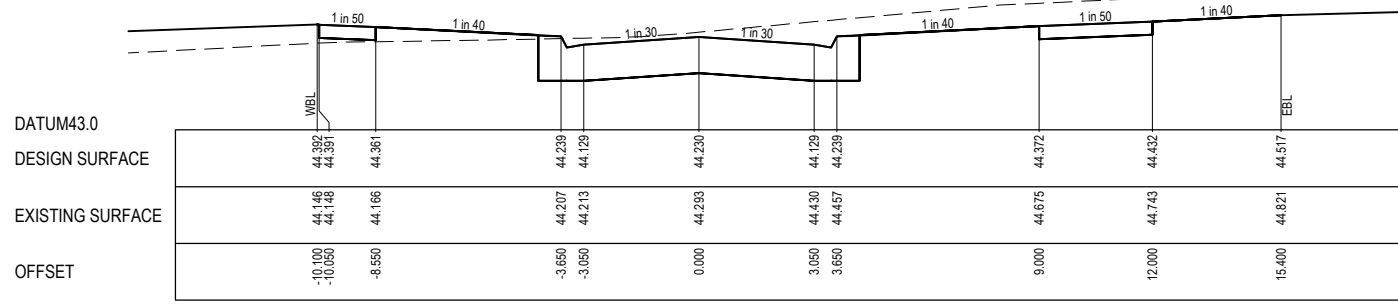

TPCH 260.144

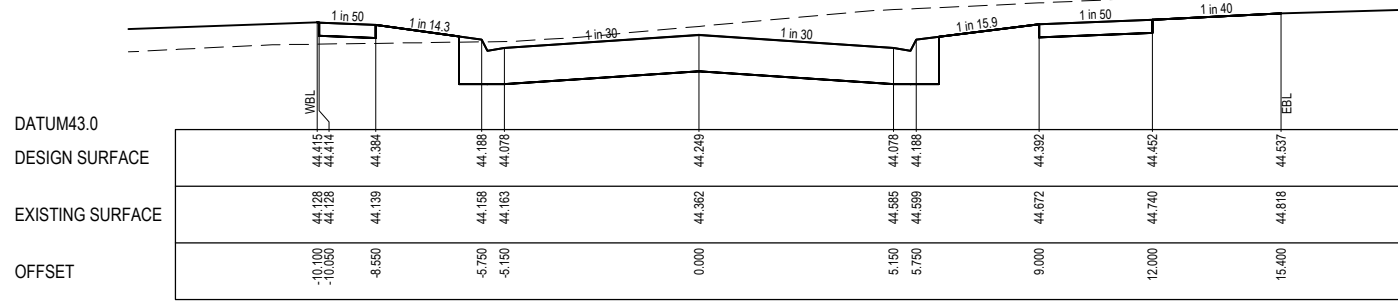

TPCH 256.321

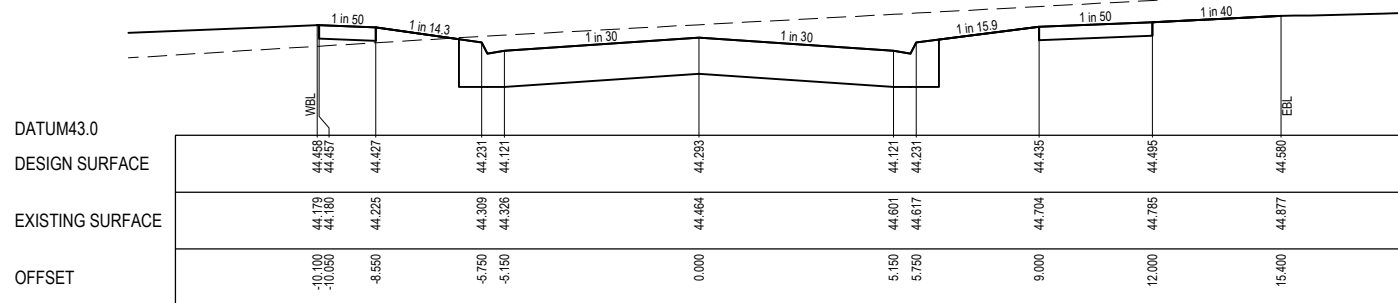

CH 242.516

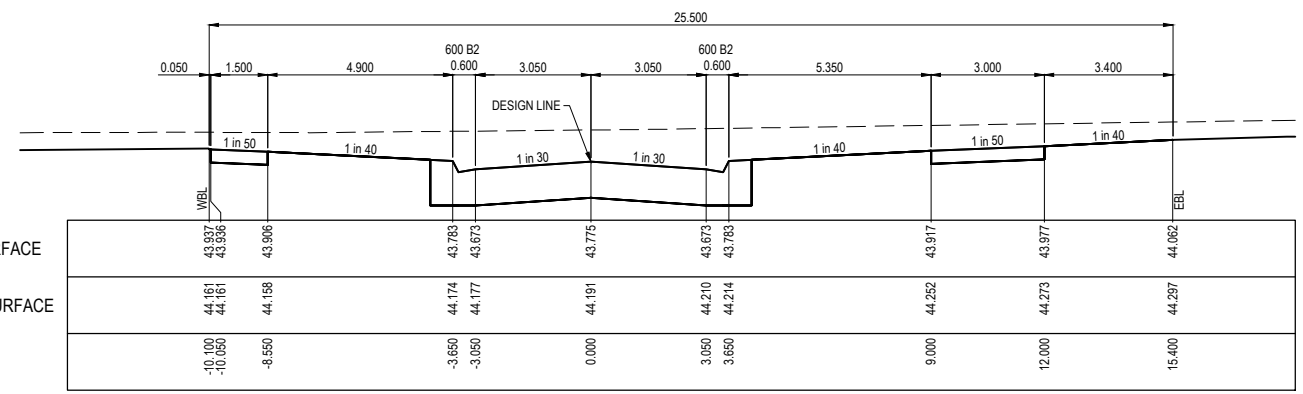

CH 351.172

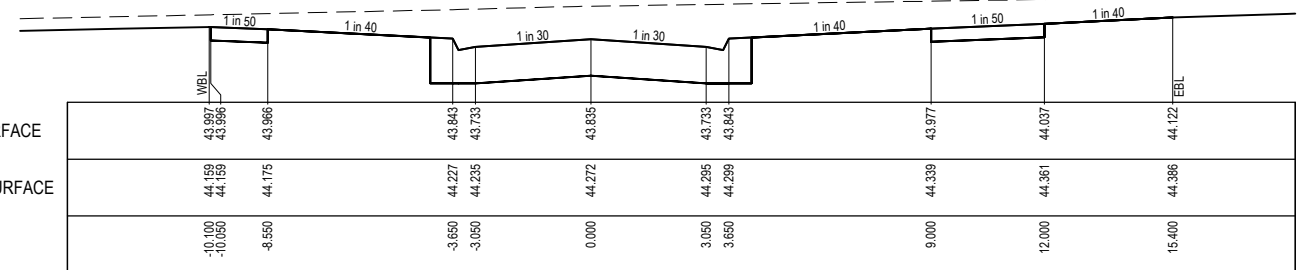

TPCH 339.203

ISSUED FOR CONSTRUCTION

© COPYRIGHT All rights reserved Beveridge Williams & Co. Pty Ltd has granted a licence to the principle to use this document for its intended purpose. No unauthorised copying is permitted											
A	ISSUED FOR CONSTRUCTION	24.02.22	M.F	M.F							
REV	DESCRIPTION	DATE	DRN.	APP.	REV	DESCRIPTION	DATE	DRN.	APP.		

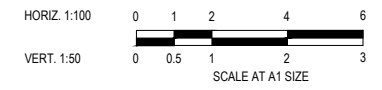

Designed By: E. BARCHAM
Date: 02.08.2021
Drawn By: N. TABUENA
Approved By: M. FELICIANO
Date: 02.08.2021
PS Number: PS848726W

1 Glenferrie Road
Malvern VIC 3144
ph: 03 9524 8888
www.beveridgewilliams.com.au

Project Details: MERIDIAN CENTRAL ESTATE
STAGE 31
CITY OF CASEY

Drawing Title: ROAD CROSS SECTIONS
BURLINA BOULEVARD

Sheet 14 of 27
Scale: 1:100 H 1:50 V @ A1
Project Ref: 1801767
Stage No: 31
Drawing No: 202
Rev: A

K:\Jobs Data\1801767 - Meridian_Eng\Stage 31\Drawings\1801767-31-200-RXS.dwg

STRUCTURAL FILL REQUIRED UNDER PAVEMENT AND FOOTPATHS WHERE CONSTRUCTED ABOVE NATURAL SURFACE. REFER GEOTECH REPORT FOR SPECIFICATION

LEGEND	
	EXISTING SURFACE
	DESIGN SURFACE
	STRUCTURAL FILL

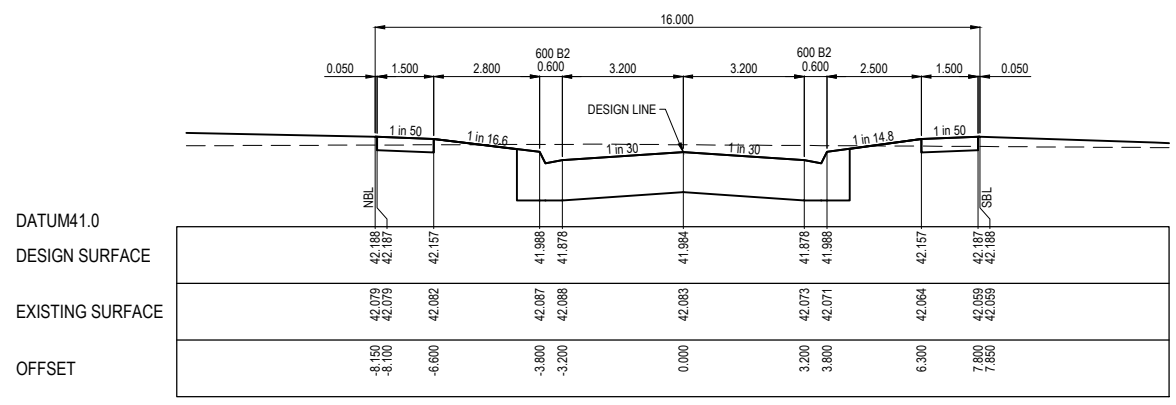

TPCH 242.663

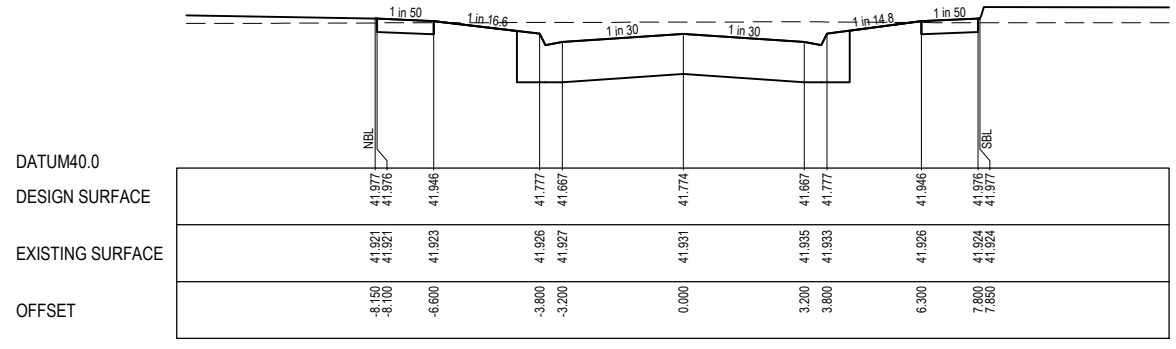

CH 225.650

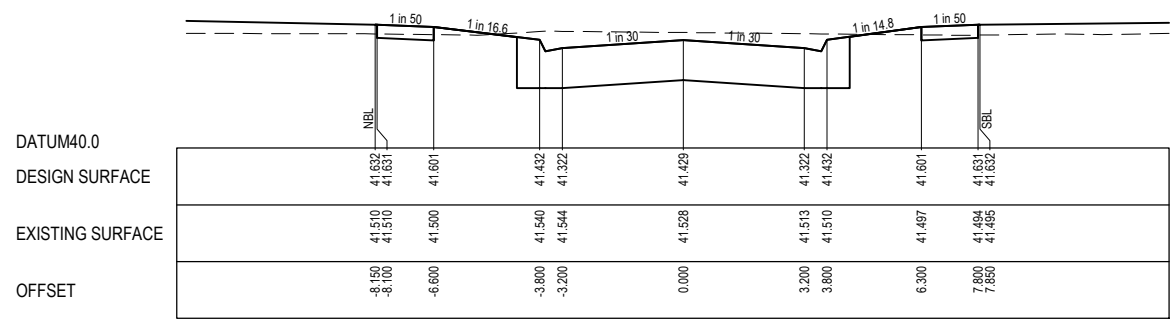

CH 202.650

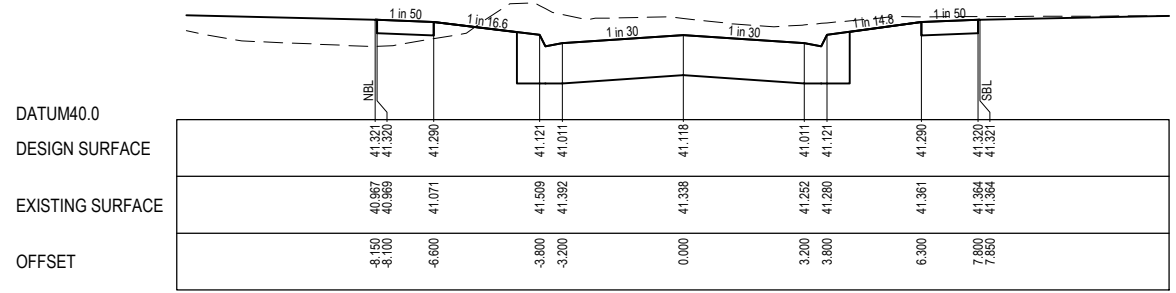

CH 179.650

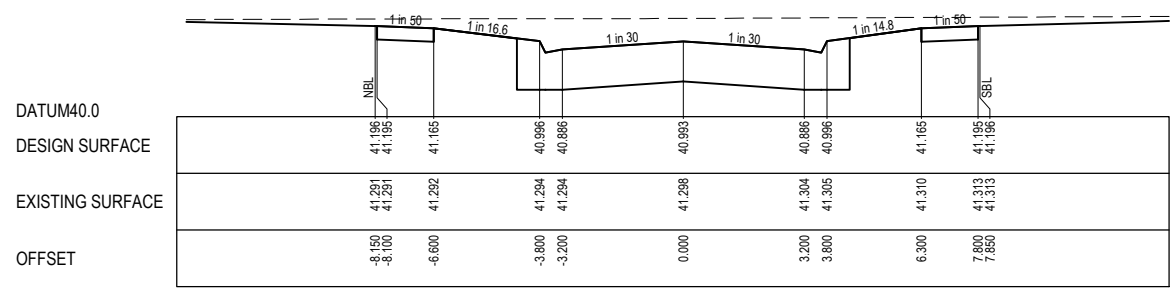

CH 167.150

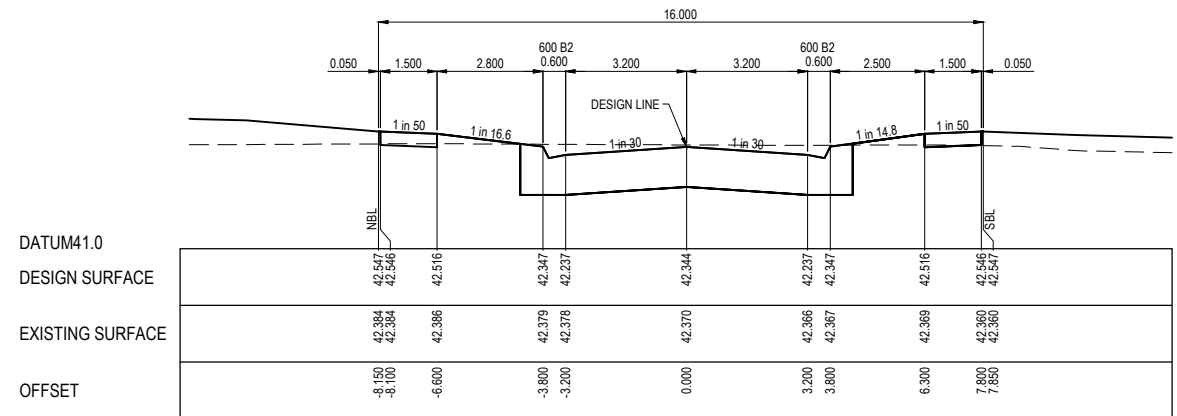

TPCH 278.616

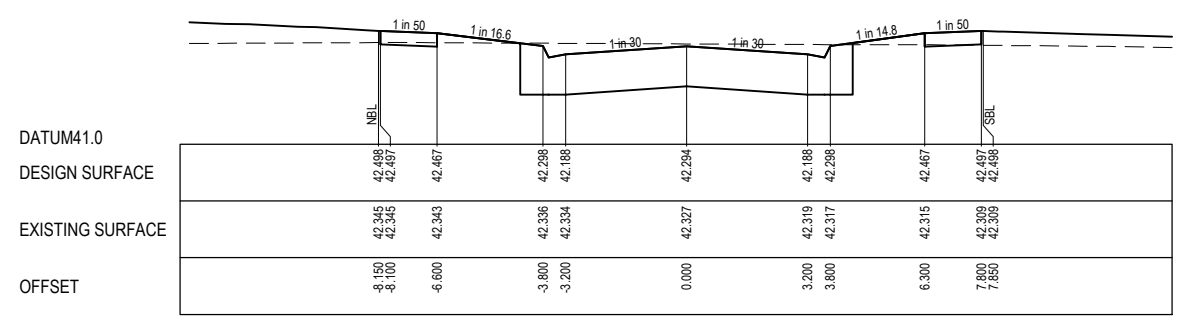

TPCH 273.653

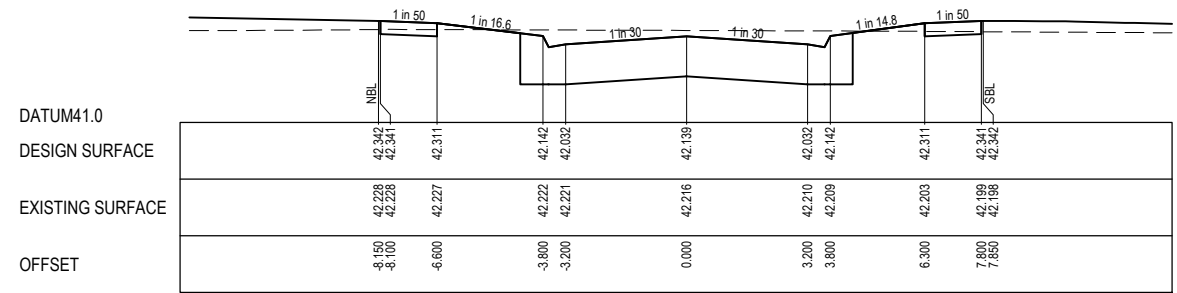

CH 258.090

ISSUED FOR CONSTRUCTION

REV	DESCRIPTION	DATE	DRN.	APP.	REV	DESCRIPTION	DATE	DRN.	APP.
A	ISSUED FOR CONSTRUCTION	24.02.22	M.F.	M.F.					

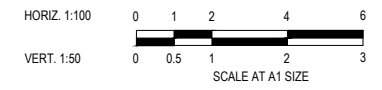

Designed Date: E. BARCHAM 02.08.2021
 Drawn: N. TABUENA
 Approved Date: M. FELICIANO 02.08.2021
 PS Number: PS848726W

BW Beveridge Williams
 1 Glenferrie Road
 Malvern VIC 3144
 ph: 03 9524 8888
 www.beveridgewilliams.com.au

Project Details	MERIDIAN CENTRAL ESTATE STAGE 31 CITY OF CASEY
Drawing Title	ROAD CROSS SECTIONS CHITTAGONG DRIVE

Sheet 15 of 27
Scale 1:100 H 1:50 V @ A1
Project Ref 1801767
Stage No 31
Drawing No 203
Rev A

K:\Jobs Data\1801767 - Meridian_Eng\Stage 31\Drawings\1801767-31-200-RXS.dwg

STRUCTURAL FILL REQUIRED UNDER PAVEMENT AND FOOTPATHS WHERE CONSTRUCTED ABOVE NATURAL SURFACE. REFER GEOTECH REPORT FOR SPECIFICATION

LEGEND	
	EXISTING SURFACE
	DESIGN SURFACE
	STRUCTURAL FILL

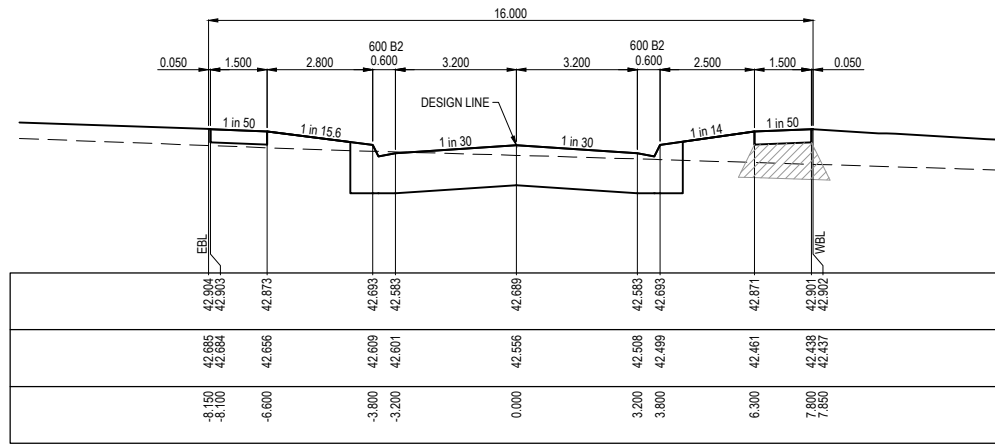

CH 61.520

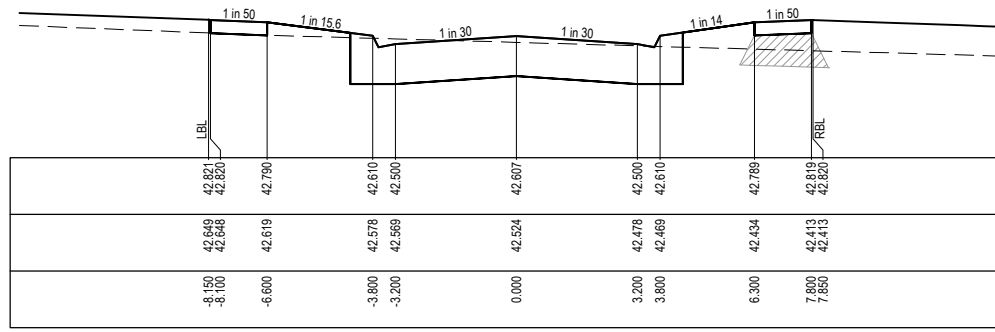

TPCH 43.739

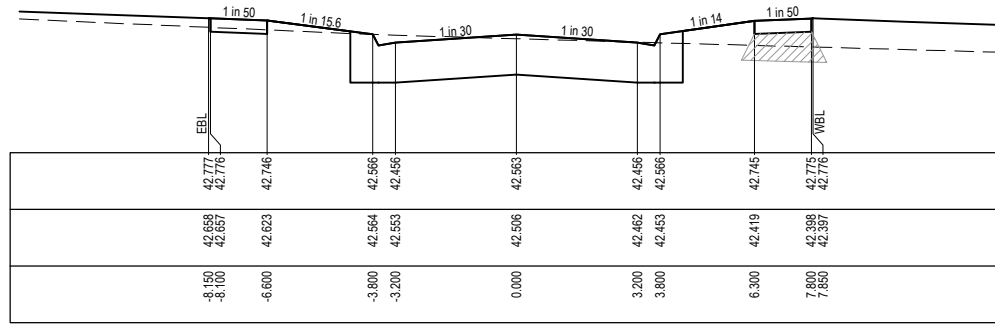

CH 34.931

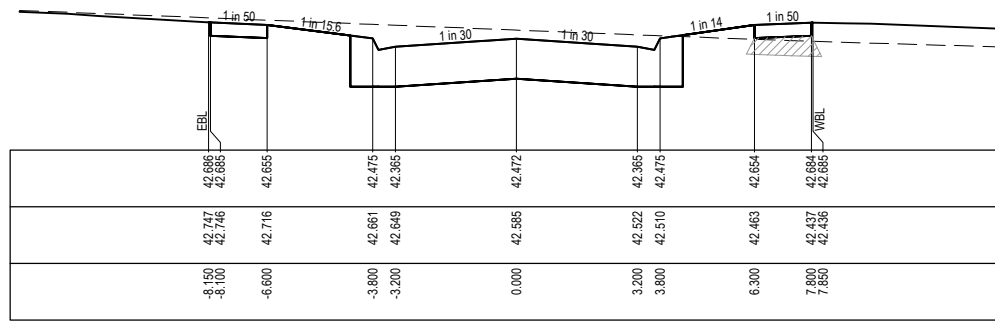

TPCH 16.679

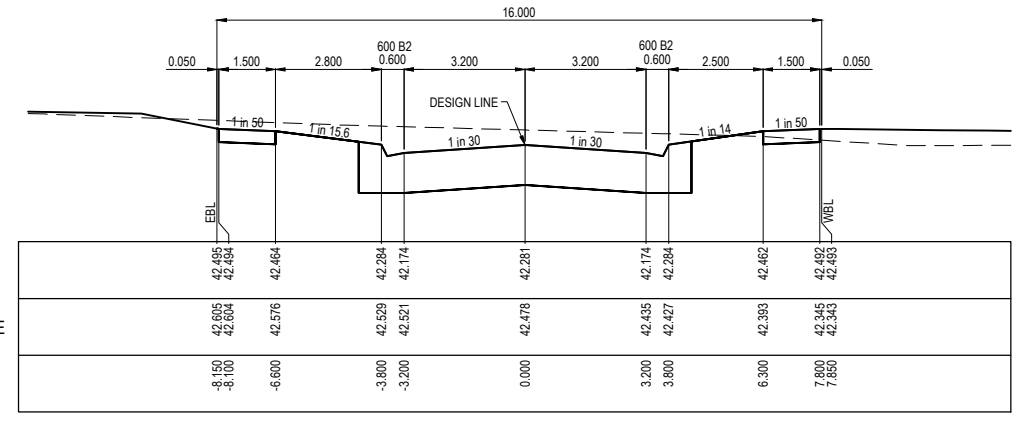

CH 99.724

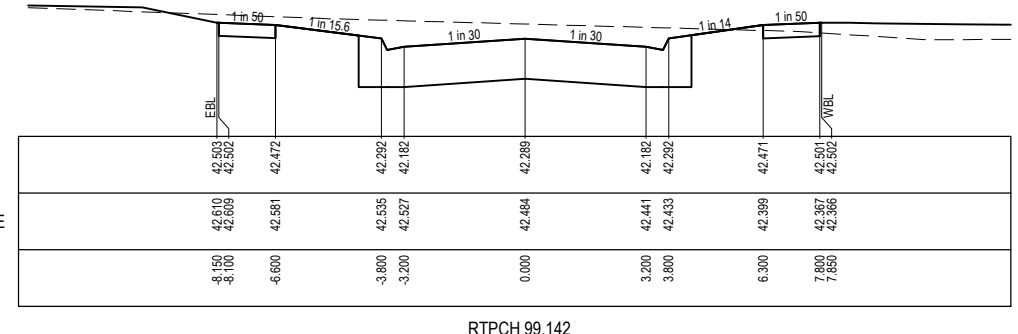

RTPCH 99.142

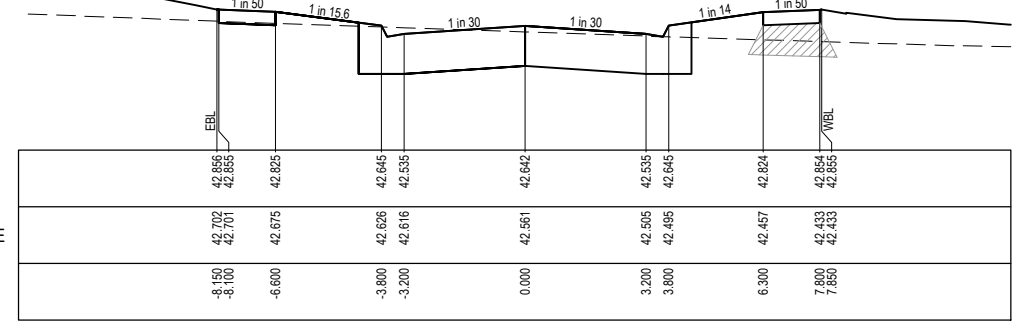

RTPCH 73.180

ISSUED FOR CONSTRUCTION

REV	DESCRIPTION	DATE	DRN.	APP.	REV	DESCRIPTION	DATE	DRN.	APP.
A	ISSUED FOR CONSTRUCTION	24.02.22	M.F.	M.F.					

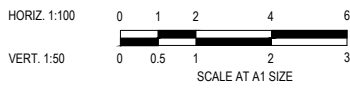

Designed Date: E. BARCHAM 02.08.2021
Drawn: N. TABUENA
Approved Date: M. FELICIANO 02.08.2021
PS Number: PS848726W



Project Details: MERIDIAN CENTRAL ESTATE STAGE 31 CITY OF CASEY
Drawing Title: ROAD CROSS SECTIONS GININ STREET

Sheet 16 of 27
Scale: 1:100 H 1:50 V @ A1
Project Ref: 1801767 Stage No: 31 Drawing No: 204 Rev: A

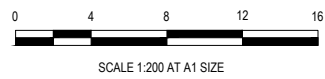
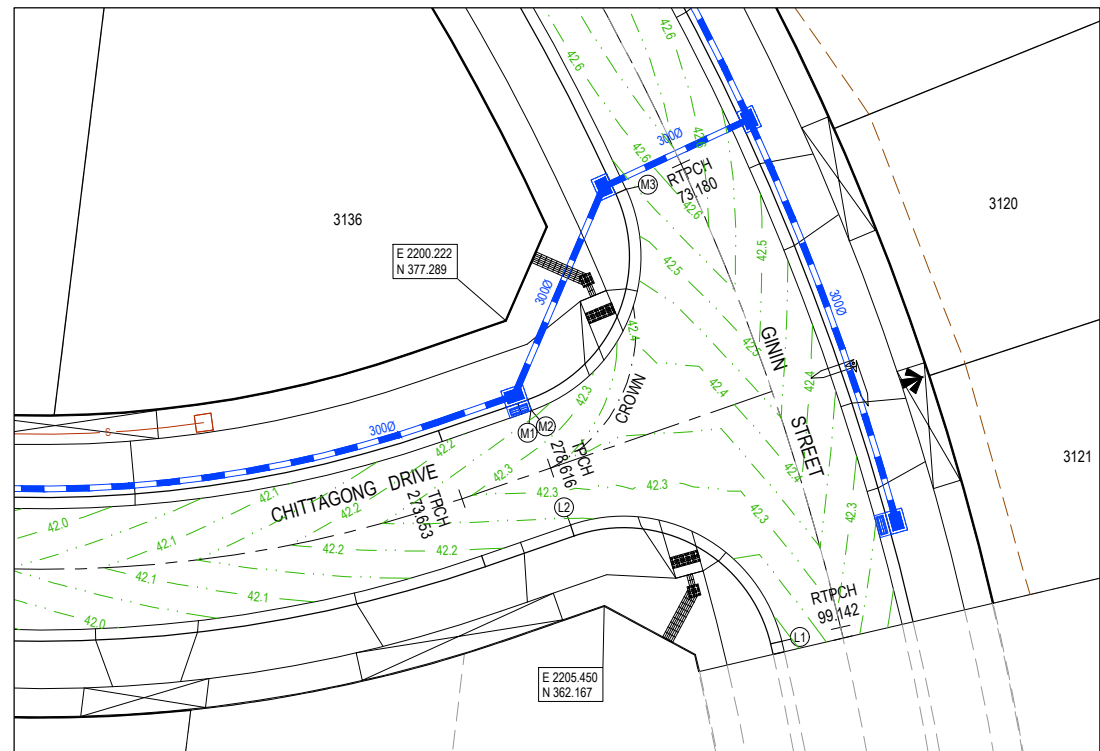
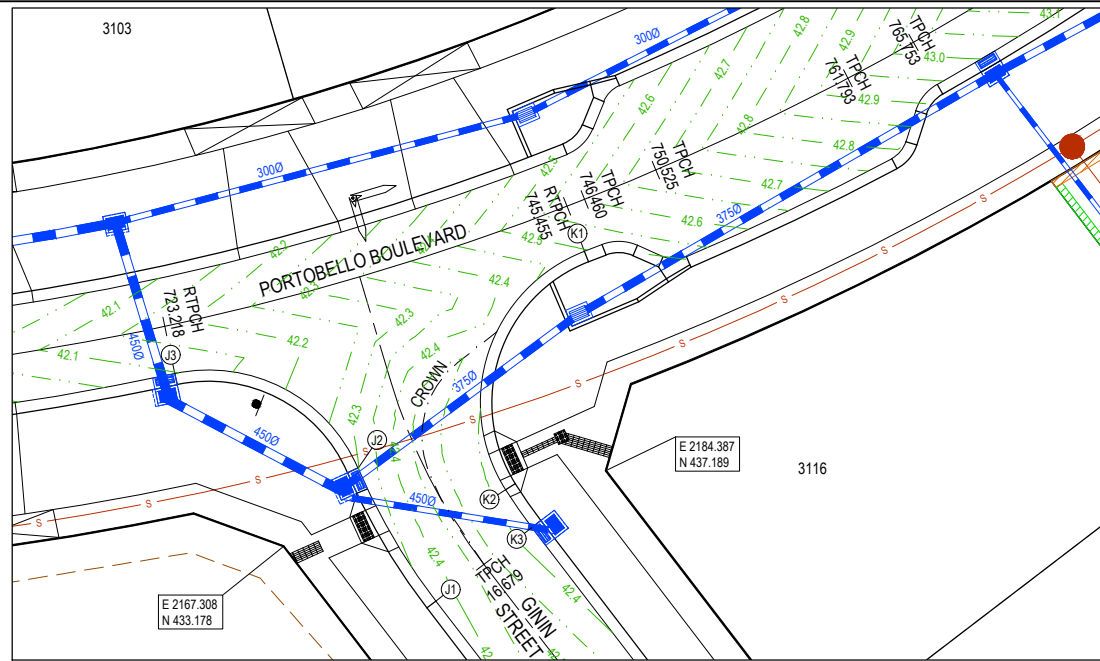

LEGEND	
	STORMWATER DRAIN, PIT & PROPERTY INLET
	MELBOURNE WATER DRAIN & PIT
	SEWER & MAINTENANCE STRUCTURES
	HOUSE DRAIN
	TACTILE PAVERS (INDICATIVE ONLY)
	EXISTING HOUSE DRAIN
	RETAINING WALL
	PAVEMENT TREATMENT
	CONCRETE EDGE STRIP WITH SUBSOIL DRAIN, 'NO ROAD' SIGN & BARRIER
	LIMIT OF WORKS
	EXISTING TREE TO BE REMOVED
	PERMANENT SURVEY MARK
	TEMPORARY BENCH MARK
	PROPOSED DRIVEWAY

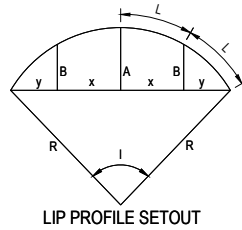

VERTICAL GEOMETRY
DATUM RL41
DESIGN LEVEL
EXISTING SURFACE
CHAINAGE

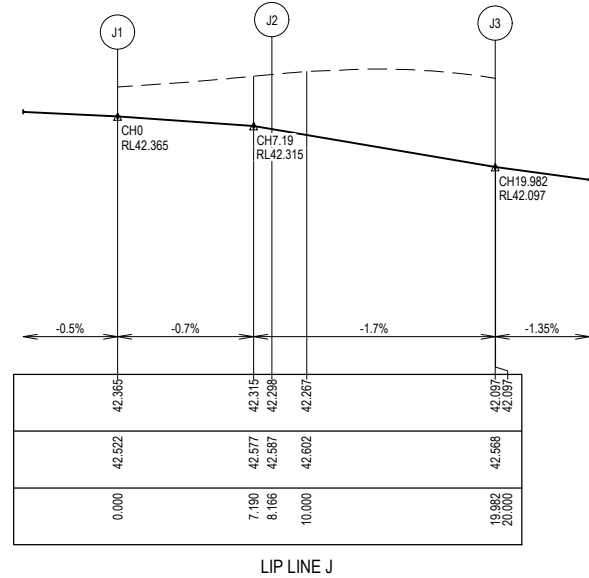

ALIGNMENT J

Point no	Easting	Northing	RL
J1	2175.374	430.290	42.365
J2	2171.254	437.317	42.298
J3	2161.561	442.320	42.097

Curve no	I	Radius	Arc	A	B	X	Y	L	Mid point RL
J1 - J2	14.093	33.200	8.166	0.251	0.188	2.040	2.033	2.042	42.336
J2 - J3	78.720	8.600	11.816	1.951	1.448	2.896	2.558	2.954	42.198

VERTICAL GEOMETRY
DATUM RL42
DESIGN LEVEL
EXISTING SURFACE
CHAINAGE

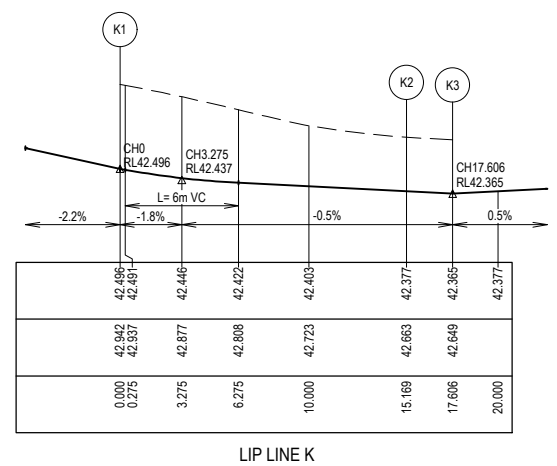

ALIGNMENT K

Point no	Easting	Northing	RL
K1	2183.236	448.786	42.496
K2	2179.965	436.180	42.377
K3	2180.456	434.180	42.365

Curve no	I	Radius	Arc	A	B	X	Y	L	Mid point RL
K1 - K2	101.063	8.600	15.169	3.133	2.311	3.671	2.968	3.792	42.415
K2 - K3	5.209	26.800	2.437	0.028	0.021	0.609	0.609	0.609	42.371

VERTICAL GEOMETRY
DATUM RL41
DESIGN LEVEL
EXISTING SURFACE
CHAINAGE

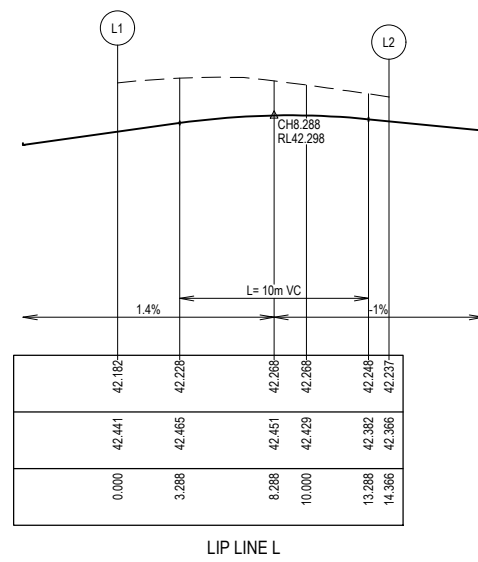

ALIGNMENT L

Point no	Easting	Northing	RL
L1	2214.836	360.327	42.182
L2	2203.659	366.468	42.237

Curve no	I	Radius	Arc	A	B	X	Y	L	Mid point RL
L1 - L2	95.713	8.600	14.366	2.829	2.090	3.488	2.889	3.592	42.264

VERTICAL GEOMETRY
DATUM RL41
DESIGN LEVEL
EXISTING SURFACE
CHAINAGE

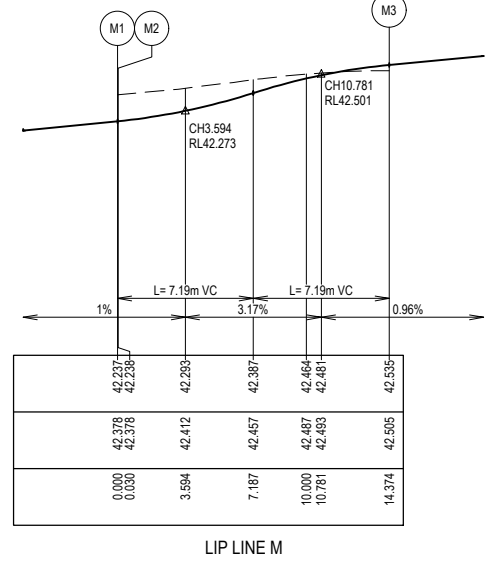

ALIGNMENT M

Point no	Easting	Northing	RL
M1	2201.567	372.517	42.237
M2	2201.595	372.526	42.238
M3	2206.603	384.240	42.535

Curve no	I	Radius	Arc	A	B	X	Y	L	Mid point RL
M2 - M3	95.569	8.600	14.345	2.821	2.085	3.483	2.886	3.586	42.387

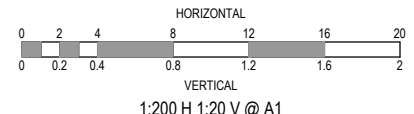

ISSUED FOR CONSTRUCTION

REV	DESCRIPTION	DATE	DRN.	APP.	REV	DESCRIPTION	DATE	DRN.	APP.
A	ISSUED FOR CONSTRUCTION	24.02.22	M.F.	M.F.					



Designed Date
E. BARCHAM
02.08.2021

Drawn
N. TABUENA

Approved Date
M. FELICIANO
02.08.2021

PS Number
PS848726W



Project Details
MERIDIAN CENTRAL ESTATE
STAGE 31
CITY OF CASEY

Project Ref
1801767

Stage No
31

Drawing No
300

Rev
A

Sheet 17 of 27

Scale
AS SHOWN

North Arrow

K:\Jobs Data\1801767 - Meridian_Eng\Stage 31\Drawings\1801767-31-300-INT.dwg

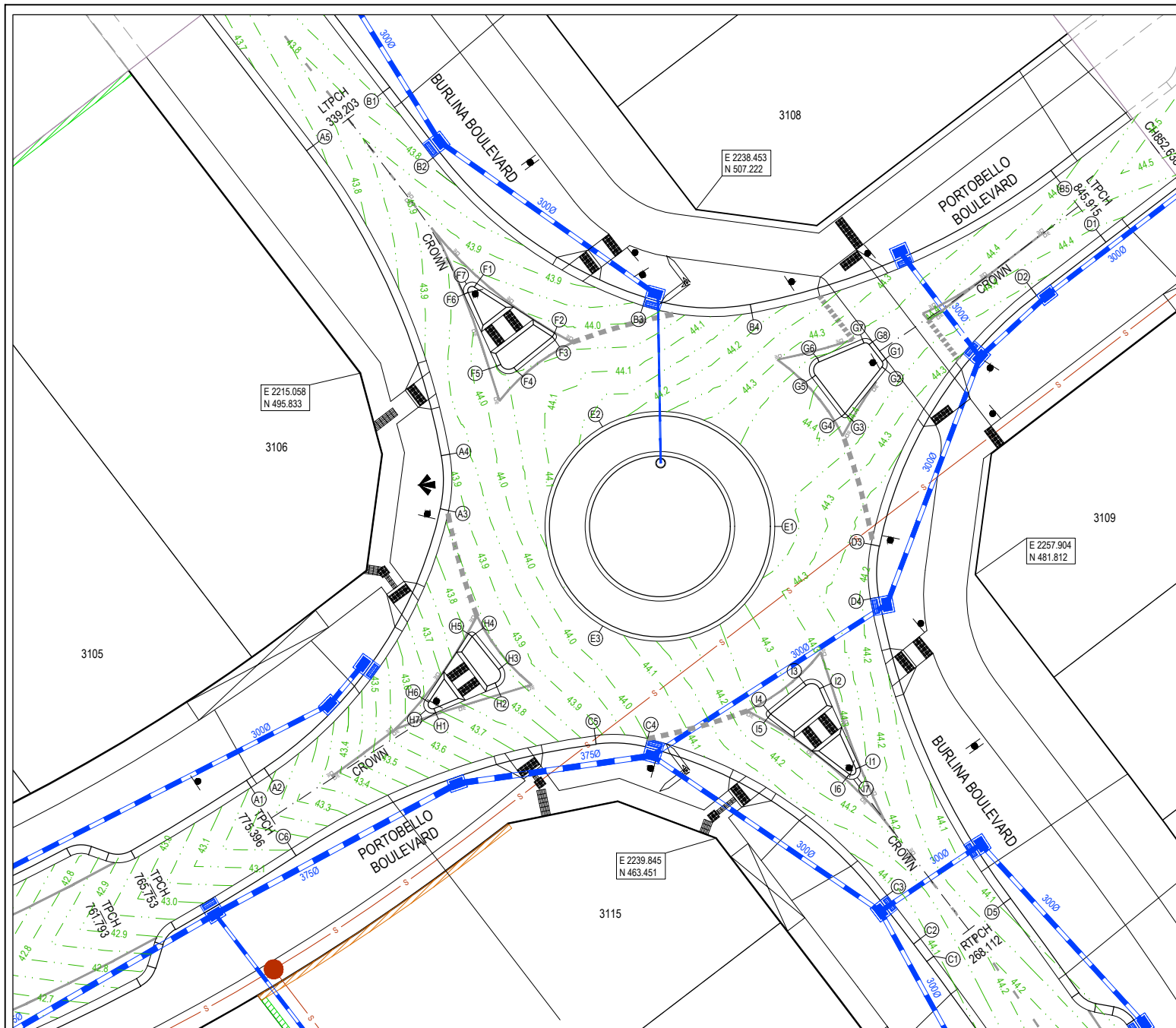

LEGEND

- STORMWATER DRAIN, PIT & PROPERTY INLET
- MELBOURNE WATER DRAIN & PIT
- SWALE DRAIN
- SEWER & MAINTENANCE STRUCTURES
- HOUSE DRAIN
- TACTILE PAVERS (INDICATIVE ONLY)
- EXISTING HOUSE DRAIN
- RETAINING WALL
- PAVEMENT TREATMENT
- CONCRETE EDGE STRIP WITH SUBSOIL DRAIN.
- "NO ROAD" SIGN & BARRIER
- LIMIT OF WORKS
- EXISTING TREE TO BE REMOVED
- PERMANENT SURVEY MARK
- TEMPORARY BENCH MARK
- PROPOSED DRIVEWAY

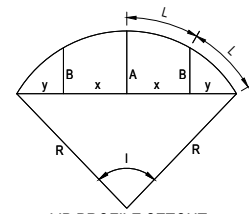

LIP PROFILE SETOUT

VERTICAL GEOMETRY
DATUM RL42

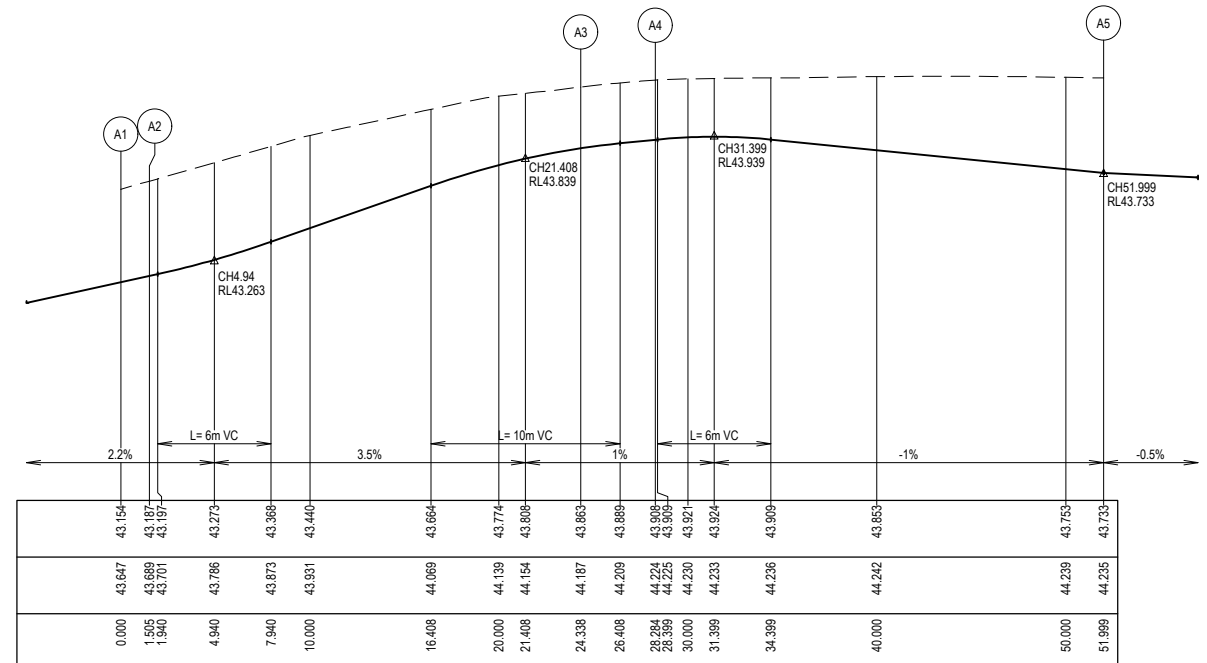

ALIGNMENT A

Point no	Easting	Northing	RL
A1	2207.469	466.992	43.154
A2	2208.721	467.828	43.187
A3	2221.233	486.270	43.863
A4	2221.305	490.190	43.908
A5	2211.807	511.678	43.733

Curve no	I	Radius	Arc	A	B	X	Y	L	Mid point RL
A1 - A2	0.628	137.450	1.505	0.002	0.002	0.376	0.376	0.376	43.171
A2 - A3	43.606	30.000	22.832	2.146	1.605	5.674	5.469	5.708	43.542
A3 - A4	22.610	10.000	3.946	0.194	0.145	0.985	0.975	0.987	43.888
A4 - A5	27.176	50.000	23.715	1.399	1.048	5.915	5.832	5.929	43.852

VERTICAL GEOMETRY
DATUM RL43

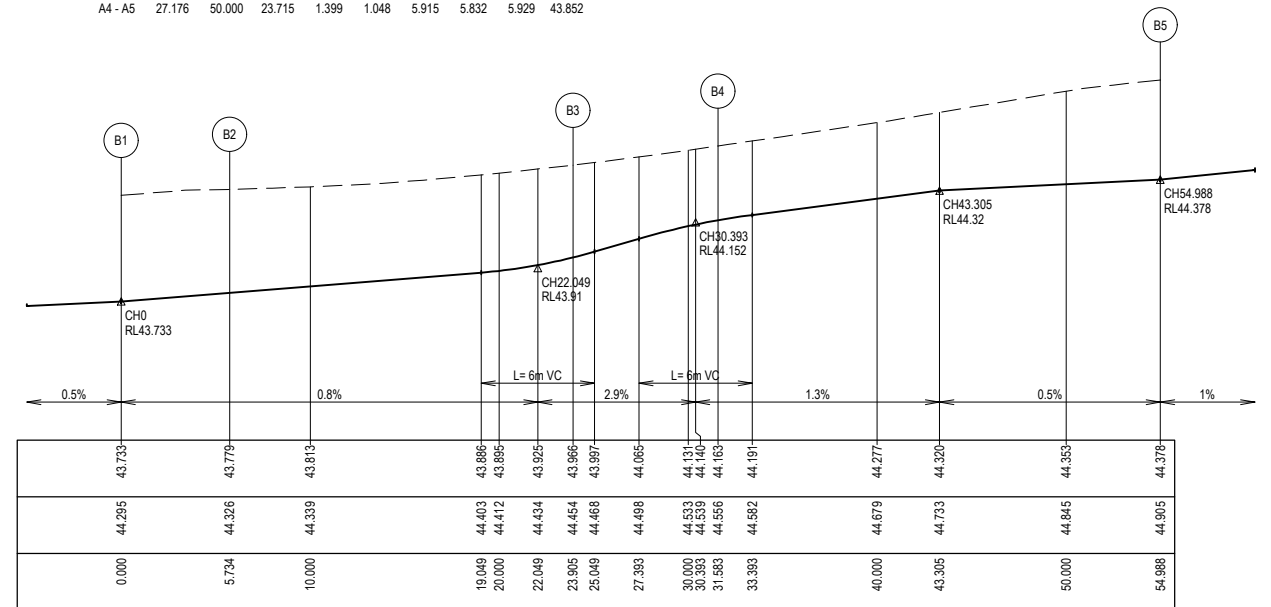

ALIGNMENT B

Point no	Easting	Northing	RL
B1	2216.651	515.385	43.733
B2	2220.136	510.832	43.779
B3	2234.756	500.514	43.966
B4	2242.341	500.033	44.163
B5	2263.524	509.475	44.378

Curve no	I	Radius	Arc	A	B	X	Y	I	Mid point RL
B2 - B3	34.704	30.000	18.171	1.365	1.022	4.525	4.422	4.543	43.852
B3 - B4	28.476	15.450	7.679	0.475	0.355	1.915	1.885	1.920	44.075
B4 - B5	26.820	50.000	23.405	1.363	1.021	5.838	5.758	5.851	44.319

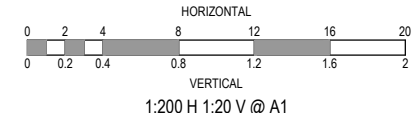

ISSUED FOR CONSTRUCTION

REV	DESCRIPTION	DATE	DRN.	APP.	REV	DESCRIPTION	DATE	DRN.	APP.
B	PRIORITY CROSSING & LIP B UPDATED	28.03.22	M.F.	M.F.					
A	ISSUED FOR CONSTRUCTION	24.02.22	M.F.	M.F.					

BROWN
PROPERTY GROUP

MERIDIAN
CENTRAL

BW Beveridge Williams

1 Glenferrie Road
Malvern VIC 3144
ph: 03 9524 8888
www.beveridgewilliams.com.au

Project Details
MERIDIAN CENTRAL ESTATE
STAGE 31
CITY OF CASEY

Drawing Title
INTERSECTION DETAILS
(SHEET 2 OF 4)

Sheet 18 of 27

Scale
AS SHOWN

Project Ref: 1801767 Stage No: 31 Drawing No: 301 Rev: B

K:\Jobs Data\1801767 - Meridian_Eng\Stage 31\Drawings\1801767-31-300-INT.dwg

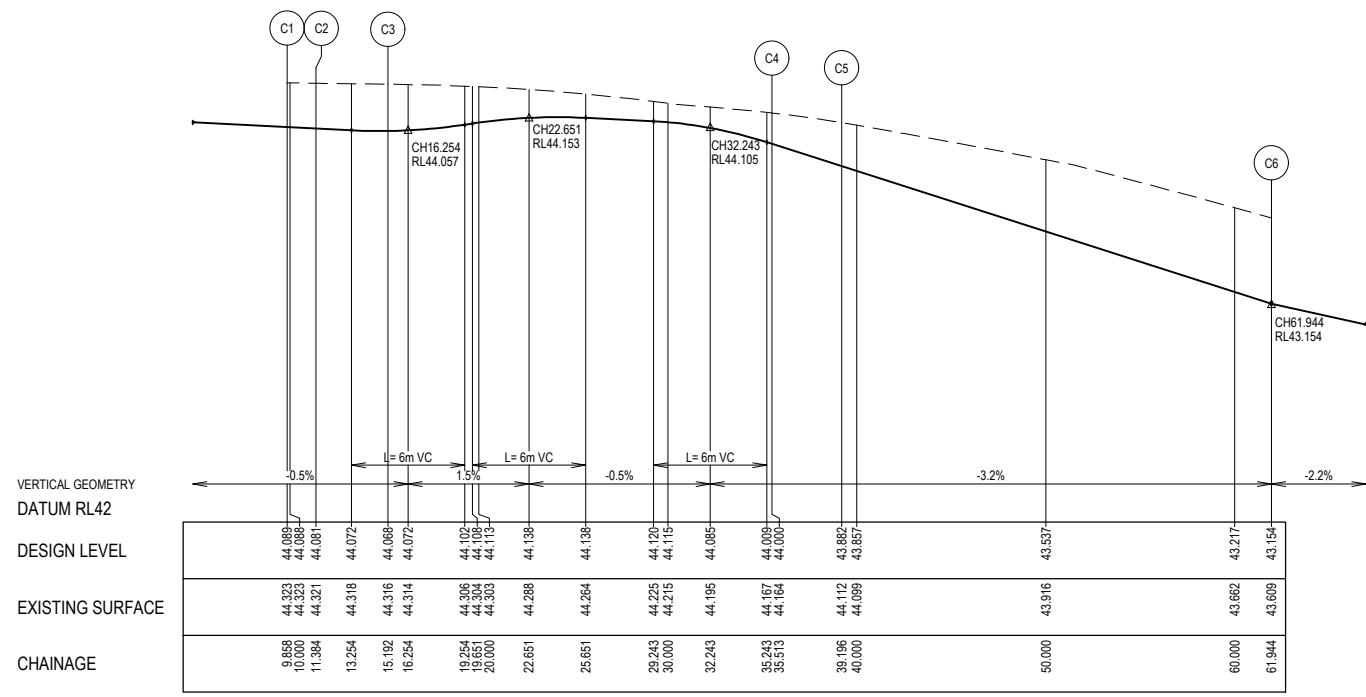

ALIGNMENT C

Point no	Easting	Northing	RL
C1	2255.001	455.241	44.089
C2	2254.077	456.457	44.081
C3	2251.763	459.480	44.068
C4	2235.075	470.384	44.000
C5	2231.418	470.589	43.882
C6	2210.278	462.735	43.154

Curve no	L	Radius	Arc	A	B	X	Y	L	Mid point RL
C1 - C2	0.422	207.050	1.527	0.001	0.001	0.382	0.382	0.382	44.085
C3 - C4	38.810	30.000	20.321	1.704	1.275	5.096	4.911	5.080	44.139
C4 - C5	21.103	10.000	3.683	0.169	0.127	0.920	0.912	0.921	43.941
C5 - C6	26.067	50.000	22.748	1.288	0.965	5.675	5.601	5.687	43.518

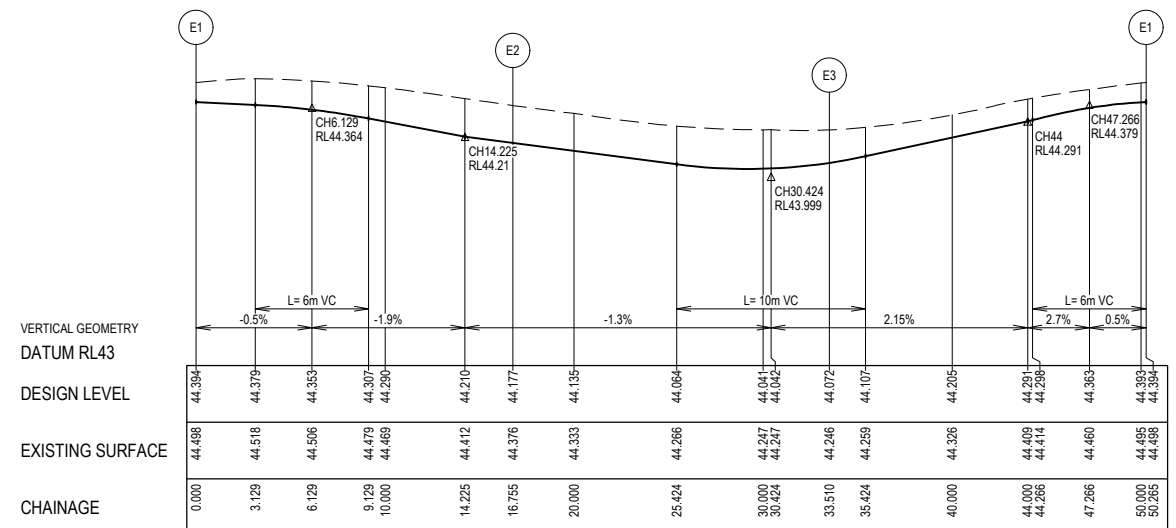

ALIGNMENT E

Point no	Easting	Northing	RL
E1	2243.950	485.156	
E2	2231.950	492.084	44.177
E3	2231.950	478.228	44.072

Curve no	L	Radius	Arc	A	B	X	Y	L	Mid point RL
E1 - E2	120.000	8.000	16.755	4.000	2.928	4.000	2.928	4.189	44.320
E2 - E3	120.000	8.000	16.755	4.000	2.928	4.000	2.928	4.189	44.068
E3 - E1	120.000	8.000	16.755	4.000	2.928	4.000	2.928	4.189	44.246

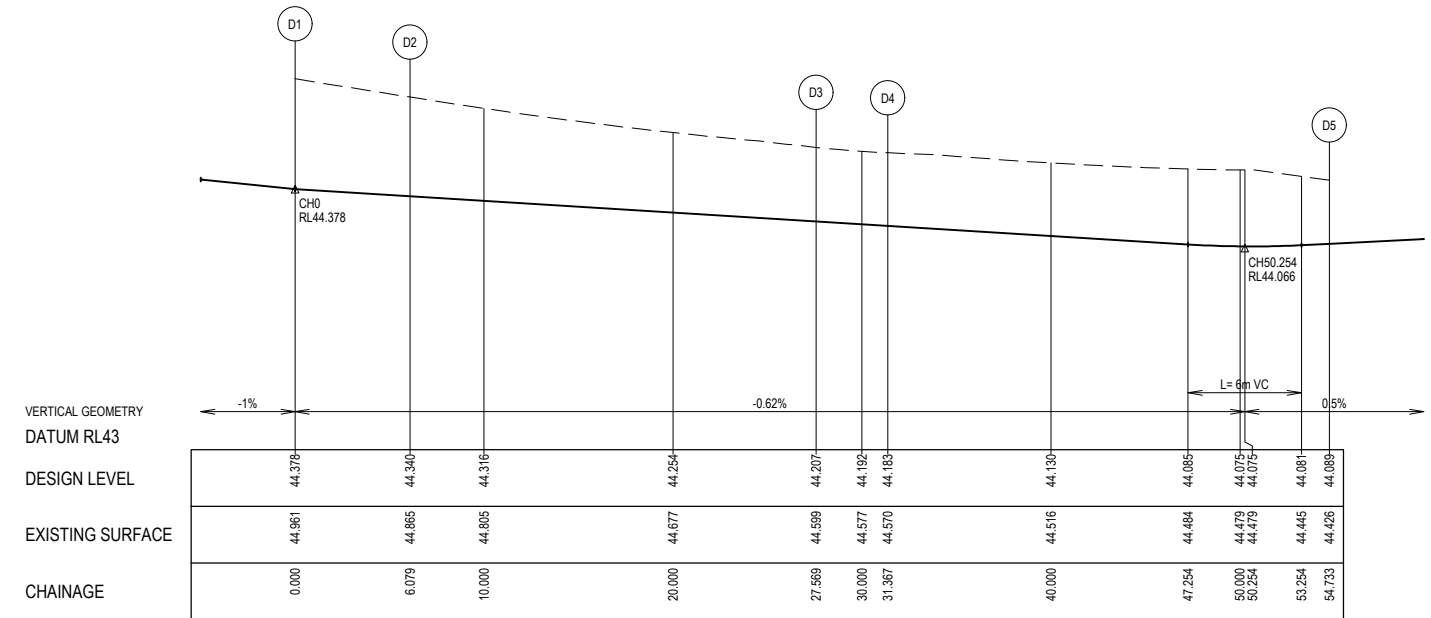

ALIGNMENT D

Point no	Easting	Northing	RL
D1	2266.623	505.425	44.378
D2	2261.796	501.730	44.340
D3	2250.636	483.901	44.207
D4	2250.594	480.127	44.183
D5	2259.872	458.913	44.089

Curve no	L	Radius	Arc	A	B	X	Y	L	Mid point RL
D2 - D3	41.042	30.000	21.490	1.904	1.424	5.344	5.173	5.372	44.274
D3 - D4	21.760	10.000	3.798	0.180	0.135	0.948	0.939	0.949	44.185
D4 - D5	26.775	50.000	23.366	1.359	1.018	5.828	5.749	5.841	44.111

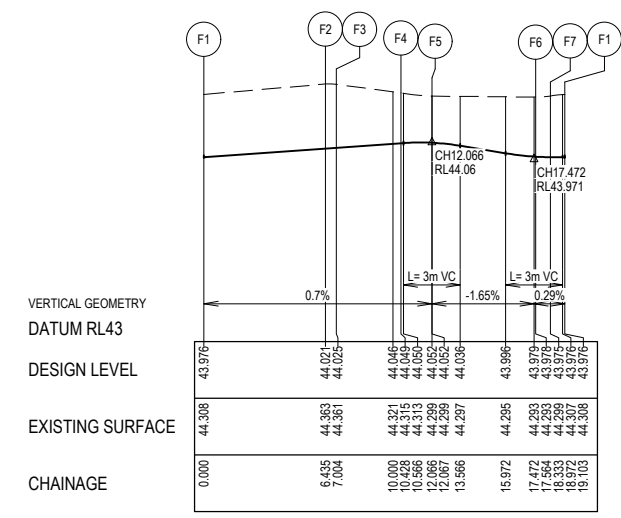
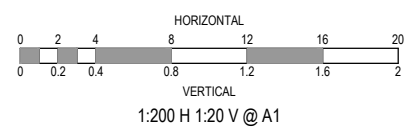

ALIGNMENT F

Point no	Easting	Northing	RL
F1	2223.176	502.077	43.976
F2	2228.602	498.617	44.021
F3	2228.629	498.130	44.025
F4	2225.959	495.987	44.049
F5	2224.576	496.317	44.052
F6	2222.307	501.324	43.978
F7	2222.461	502.025	43.975

Curve no	L	Radius	Arc	A	B	X	Y	L	Mid point RL
F2 - F3	108.706	0.300	0.569	0.125	0.092	0.137	0.107	0.142	44.023
F4 - F5	104.387	0.900	1.640	0.348	0.257	0.396	0.315	0.410	44.053
F6 - F7	73.454	0.600	0.769	0.119	0.089	0.189	0.170	0.192	43.976
F7 - F1	73.454	0.600	0.769	0.119	0.089	0.189	0.170	0.192	43.975

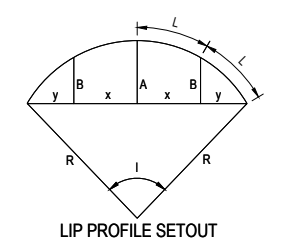

ISSUED FOR CONSTRUCTION

REV	DESCRIPTION	DATE	DRN.	APP.	REV	DESCRIPTION	DATE	DRN.	APP.
B	LIP D UPDATED	28.03.22	M.F.	M.F.					
A	ISSUED FOR CONSTRUCTION	24.02.22	M.F.	M.F.					

BROWN PROPERTY GROUP

MERIDIAN CENTRAL

Designed Date: E. BARCHAM 02.08.2021

Drawn: N. TABUENA

Approved Date: M. FELICIANO 02.08.2021

PS Number: PS848726W

Beveridge Williams

1 Glenferrie Road
Malvern VIC 3144
ph: 03 9524 8888
www.beveridgewilliams.com.au

Project Details: MERIDIAN CENTRAL ESTATE STAGE 31 CITY OF CASEY

Drawing Title: INTERSECTION DETAILS (SHEET 3 OF 4)

Sheet 19 of 27

Scale: AS SHOWN

Project Ref: 1801767 Stage No: 31 Drawing No: 302 Rev: B

K:\Jobs Data\1801767 - Meridian_Eng\Stage 31\Drawings\1801767-31-300-INT.dwg

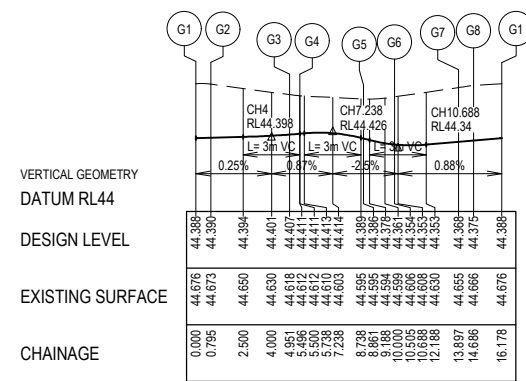

LIP LINE G

ALIGNMENT G

Point no	Easting	Northing	RL
G1	2251.650	496.822	44.388
G2	2251.643	496.085	44.390
G3	2249.058	492.830	44.407
G4	2248.585	492.834	44.411
G5	2246.540	495.506	44.386
G6	2246.306	496.892	44.354
G7	2250.034	498.196	44.368
G8	2250.743	498.007	44.375

Curve no	I	Radius	Arc	A	B	X	Y	I	Mid point RL
G1 - G2	75.890	0.600	0.795	0.127	0.094	0.195	0.174	0.199	44.389
G3 - G4	104.110	0.300	0.545	0.116	0.085	0.132	0.105	0.136	44.409
G5 - G6	104.655	0.900	1.644	0.350	0.258	0.397	0.316	0.411	44.367
G7 - G8	75.345	0.600	0.789	0.125	0.093	0.194	0.173	0.197	44.372

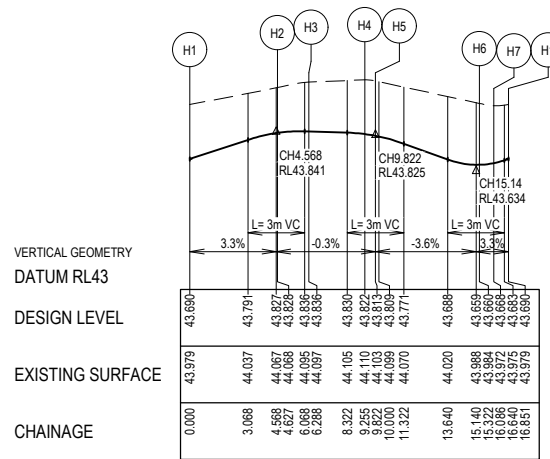

LIP LINE H

ALIGNMENT H

Point no	Easting	Northing	RL
H1	2220.324	472.197	43.690
H2	2224.587	473.994	43.828
H3	2224.941	475.386	43.836
H4	2223.087	477.703	43.822
H5	2222.602	477.680	43.813
H6	2219.589	473.079	43.660
H7	2219.630	472.366	43.668

Curve no	I	Radius	Arc	A	B	X	Y	L	Mid point RL
H2 - H3	105.791	0.900	1.662	0.357	0.263	0.401	0.317	0.415	43.836
H4 - H5	108.132	0.300	0.566	0.124	0.091	0.136	0.107	0.142	43.818
H6 - H7	73.038	0.600	0.765	0.118	0.088	0.188	0.169	0.191	43.662
H7 - H1	73.038	0.600	0.765	0.118	0.088	0.188	0.169	0.191	43.678

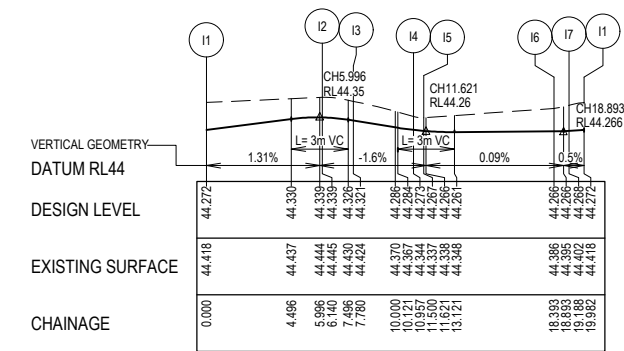

LIP LINE I

ALIGNMENT I

Point no	Easting	Northing	RL
I1	2249.855	468.402	44.272
I2	2247.321	473.994	44.339
I3	2245.938	474.324	44.321
I4	2243.461	472.335	44.273
I5	2243.467	471.862	44.267
I6	2248.944	467.677	44.266
I7	2249.682	467.684	44.268

Curve no	I	Radius	Arc	A	B	X	Y	L	Mid point RL
I2 - I3	104.414	0.900	1.640	0.348	0.257	0.396	0.315	0.410	44.333
I4 - I5	103.831	0.300	0.544	0.115	0.085	0.131	0.105	0.136	44.270
I6 - I7	75.878	0.600	0.795	0.127	0.094	0.195	0.174	0.199	44.266
I7 - I1	75.878	0.600	0.795	0.127	0.094	0.195	0.174	0.199	44.270

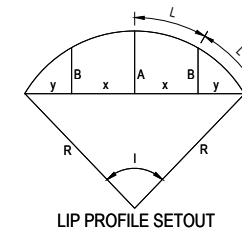
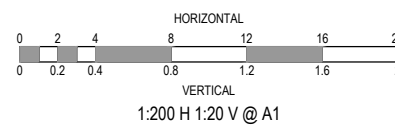

ISSUED FOR CONSTRUCTION

REV	DESCRIPTION	DATE	DRN.	APP.	REV	DESCRIPTION	DATE	DRN.	APP.
B	LIP G UPDATED	28.03.22	M.F.	M.F.					
A	ISSUED FOR CONSTRUCTION	24.02.22	M.F.	M.F.					



Designed Date: E. BARCHAM 02.08.2021
 Drawn: N. TABUENA
 Approved Date: M. FELICIANO 02.08.2021
 PS Number: PS848726W



Project Details: MERIDIAN CENTRAL ESTATE STAGE 31 CITY OF CASEY
 Drawing Title: INTERSECTION DETAILS (SHEET 4 OF 4)

Sheet 20 of 27
 Scale: AS SHOWN
 Project Ref: 1801767 Stage No: 31 Drawing No: 303 Rev: B



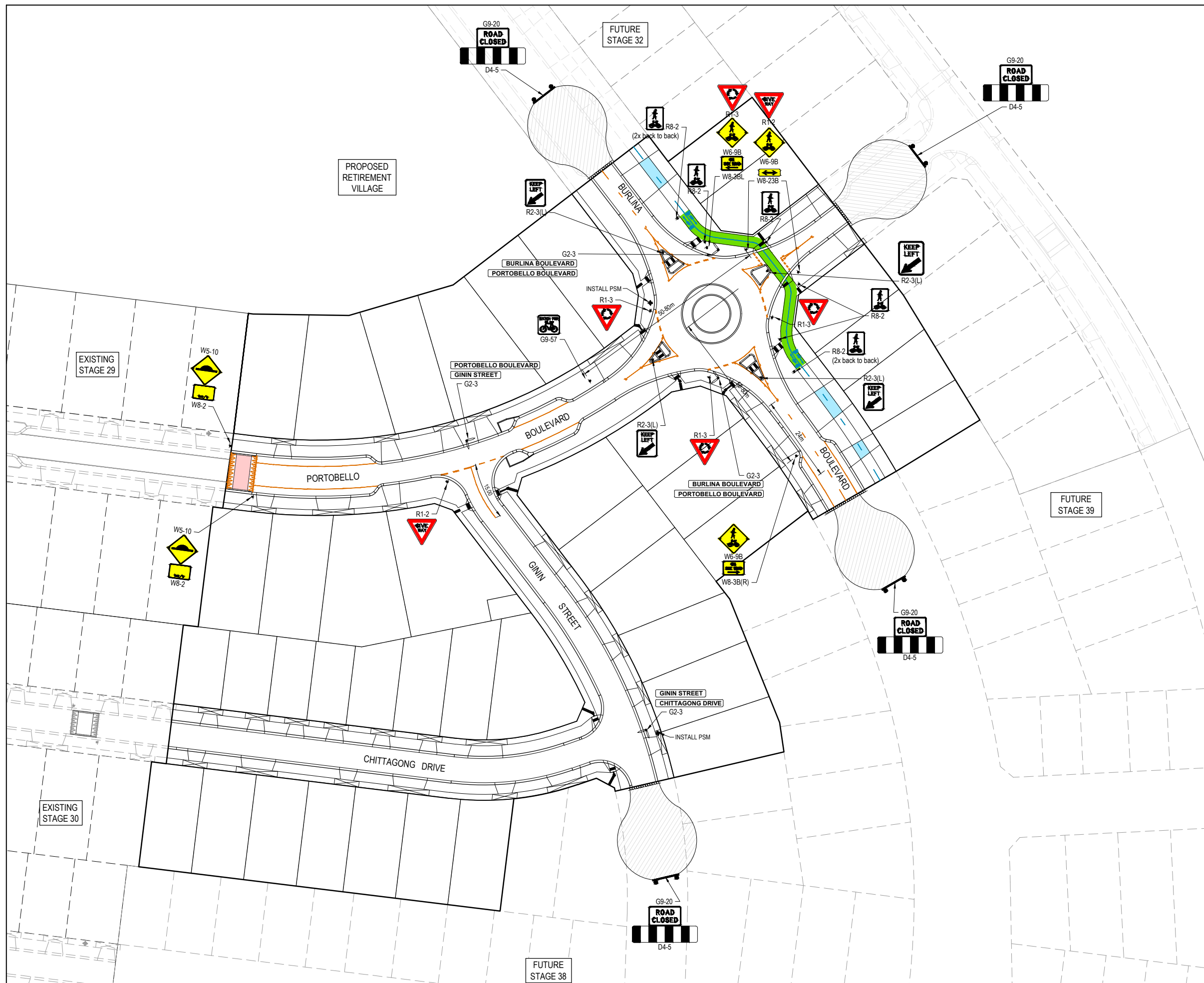

- NOTES**
1. RRPMS AT MAX 6m SPACING.
 2. LINEMARKING TO BE EXTENDED AT LEAST 6m FROM THE TANGENT POINT
 3. LINEMARKING IN ACCORDANCE WITH AS1742.
 4. TGS TO BE INSTALLED IN ACCORDANCE WITH VICROADS RDN 06-06 - JULY 2010
 5. ALL STREET NAME SIGNS AT INTERSECTIONS TO INCLUDE RELEVANT STREET NUMBERING.
 6. ALL LINE MARKING PAINT SHALL BE LONG LIFE TYPE. LATERAL WORKS AND ARROWS BEING COLD APPLIED PLASTIC TROWELLED INTO PLACE (MATERIAL DEGADUR PLASTELINE) AND LONGITUDINAL LINES BEING EXTRUDED THERMOPLASTIC MATERIAL.

ISSUED FOR CONSTRUCTION

REV	DESCRIPTION	DATE	DRN.	APP.	REV	DESCRIPTION	DATE	DRN.	APP.
B	PRIORITY CROSSING UPDATED	28.03.22	M.F	M.F					
A	ISSUED FOR CONSTRUCTION	24.02.22	M.F	M.F					

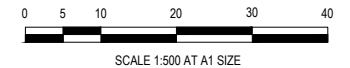

Designed Date: E. BARCHAM 02.08.2021
 Drawn: N. TABUENA
 Approved Date: M. FELICIANO 02.08.2021
 PS Number: PS848726W

BW Beveridge Williams
 1 Glenferrie Road
 Malvern VIC 3144
 ph: 03 9524 8888
 www.beveridgewilliams.com.au

Project Details: MERIDIAN CENTRAL ESTATE
 STAGE 31
 CITY OF CASEY
 Drawing Title: SIGNAGE & LINE MARKING PLANS

Sheet 21 of 27		
Scale: 1:500 @ A1		
Project Ref: 1801767	Stage No: 31	Drawing No: 350
		Rev: B

K:\Jobs Data\1801767 - Meridian_Eng\Stage 31\Drawings\1801767-31-350-LMP.dwg

NOTES:
 ALL STORMWATER DRAINS UP TO AND INCLUDING 750mm DIA. ARE TO BE CLASS 2 R.R.J. PIPES UNLESS NOTED OTHERWISE.

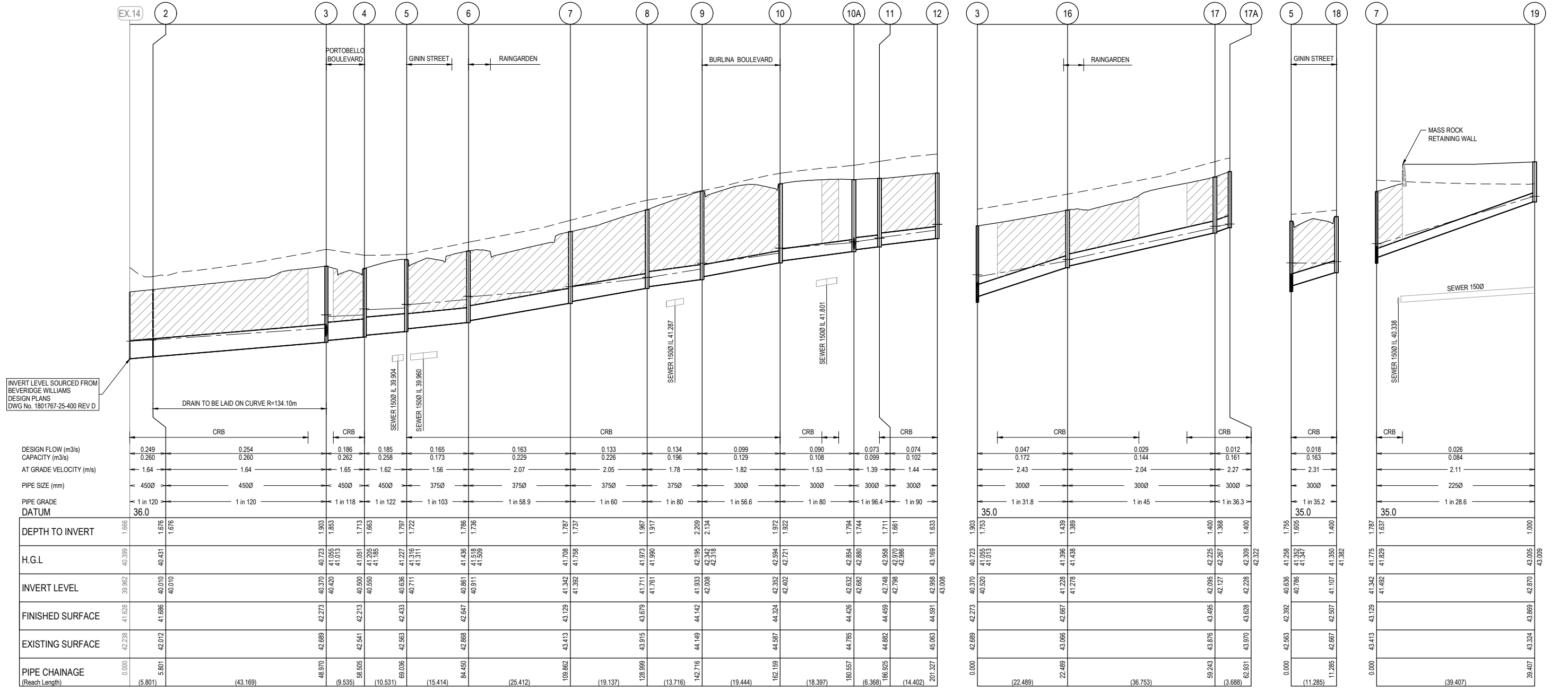
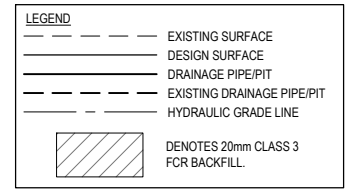

INVERT LEVEL SOURCED FROM BEVERIDGE WILLIAMS DESIGN PLANS DWG No. 1801767-25-400 REV D

DESIGN FLOW (m3/s)	CAPACITY (m3/s)	AT GRADE VELOCITY (m/s)	PIPE SIZE (mm)	PIPE GRADE DATUM	DEPTH TO INVERT	H.G.L.	INVERT LEVEL	FINISHED SURFACE	EXISTING SURFACE	PIPE CHAINAGE (Reach Length)
0.249	0.260	1.64	4500	1 in 120	1.666	40.359	39.952	41.628	42.238	0.000
0.254	0.260	1.64	4500	1 in 120	1.676	40.431	40.010	41.686	42.012	5.801
0.186	0.262	1.65	4500	1 in 118	1.853	40.723	40.420	42.273	42.689	48.970
0.185	0.258	1.62	4500	1 in 122	1.713	41.051	40.500	42.213	42.541	58.505
0.165	0.173	1.56	3750	1 in 103	1.797	41.227	40.636	42.433	42.563	69.036
0.163	0.229	2.07	3750	1 in 58.9	1.722	41.316	40.711	42.433	42.563	69.036
0.133	0.226	2.05	3750	1 in 60	1.787	41.708	41.342	43.129	43.413	109.862
0.134	0.196	1.78	3750	1 in 80	1.737	41.990	41.761	43.679	43.915	128.999
0.099	0.129	1.82	3000	1 in 56.6	2.209	42.195	41.933	44.142	44.142	142.716
0.090	0.108	1.53	3000	1 in 80	1.972	42.594	42.352	44.324	44.587	162.159
0.073	0.099	1.39	3000	1 in 96.4	1.794	42.854	42.632	44.426	44.785	180.557
0.074	0.102	1.44	3000	1 in 90	1.744	42.890	42.667	44.459	44.882	186.925
					1.661	42.970	42.798	44.591	45.063	201.327
					1.633	43.169	42.958	44.591	45.063	201.327

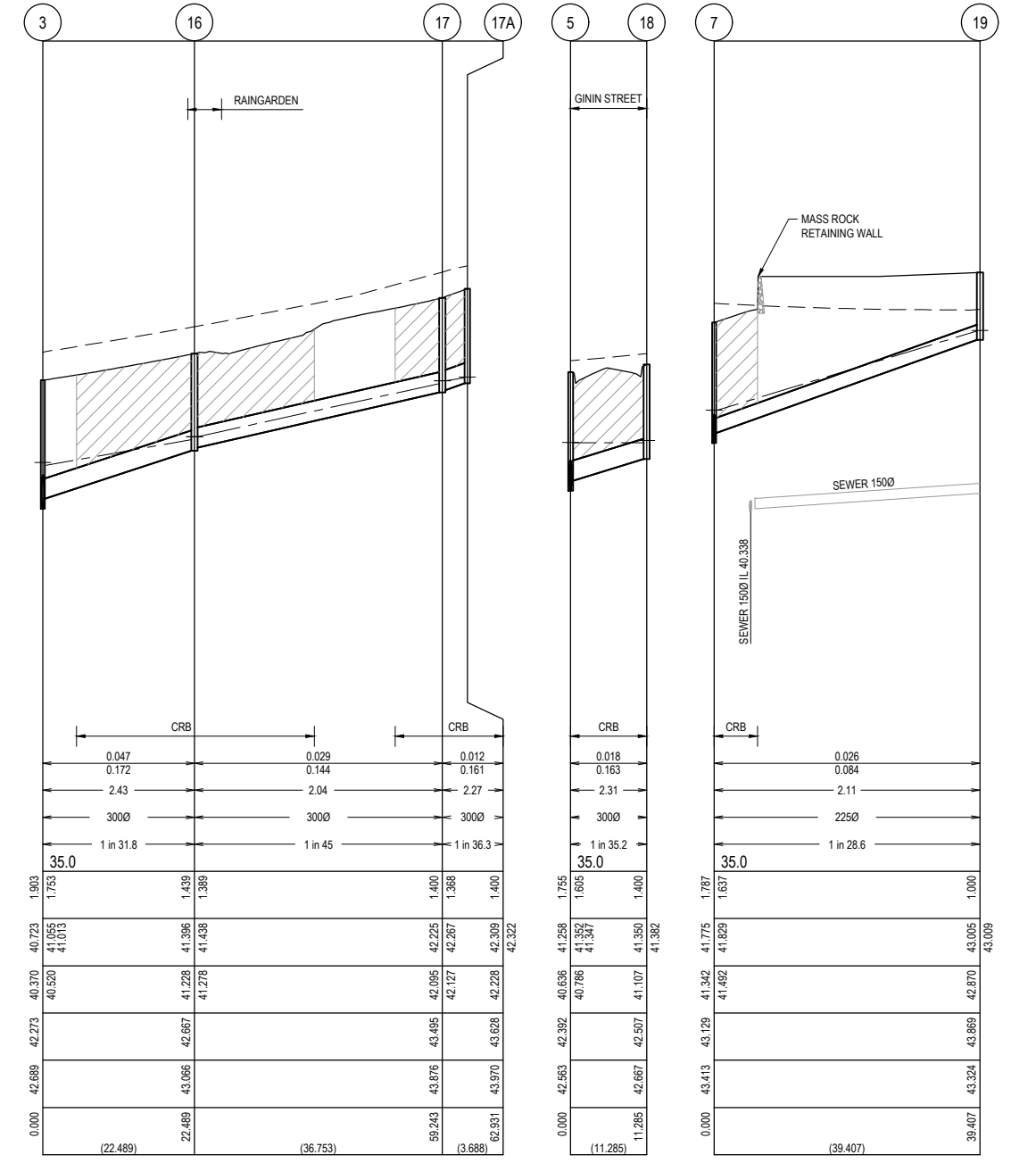

ISSUED FOR CONSTRUCTION

© COPYRIGHT All rights reserved
 Beveridge Williams & Co. Pty Ltd has granted a licence to the principle to use this document for its intended purpose.
 No unauthorised copying is permitted.

REV	DESCRIPTION	DATE	DRN.	APP.	REV	DESCRIPTION	DATE	DRN.	APP.
A	ISSUED FOR CONSTRUCTION	24.02.22	M.F.	M.F.					

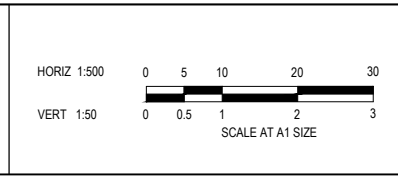

Designed Date: E. BARCHAM 02.08.2021
 Drawn: N. TABUENA
 Approved Date: M. FELICIANO 02.08.2021
 PS Number: PS848726W

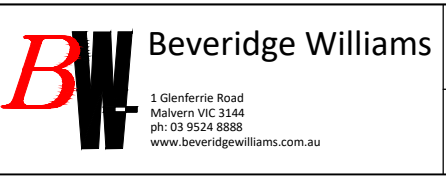

Project Details: MERIDIAN CENTRAL ESTATE
 STAGE 31
 CITY OF CASEY
 Drawing Title: DRAINAGE LONGITUDINAL SECTIONS (SHEET 1 OF 5)

Sheet 22 of 27
 Scale: 1:500 H 1:50 V @ A1
 Project Ref: 1801767
 Stage No: 31
 Drawing No: 400
 Rev: A

K:\Jobs Data\1801767 - Meridian_Eng\Stage 31\Drawings\1801767-31-400-DLS.dwg

NOTES:
 ALL STORMWATER DRAINS UP TO AND INCLUDING 750mm DIA. ARE TO BE CLASS 2 R.R.J. PIPES UNLESS NOTED OTHERWISE.

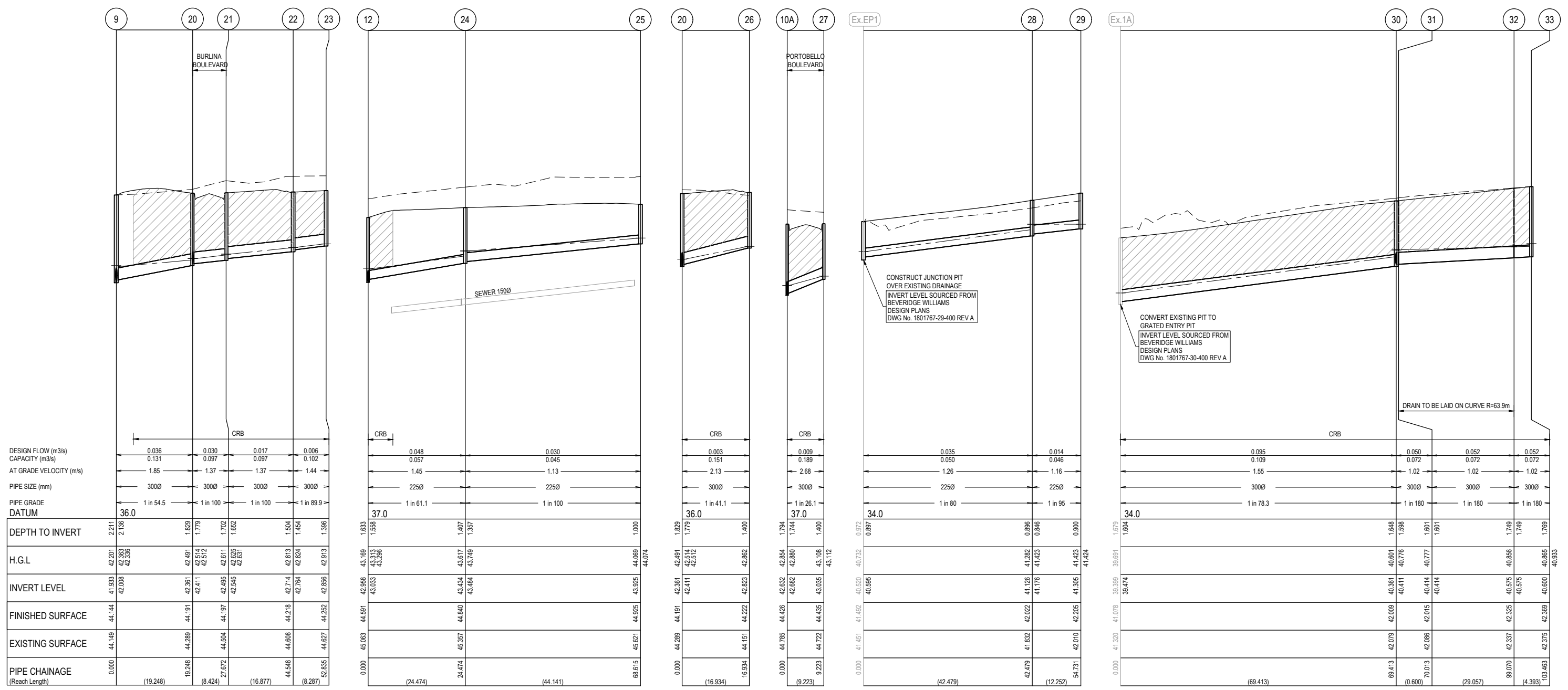
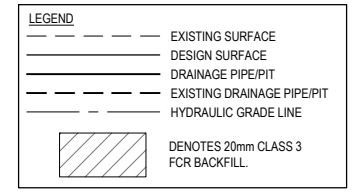

DESIGN FLOW (m3/s)	CAPACITY (m3/s)	AT GRADE VELOCITY (m/s)	PIPE SIZE (mm)	PIPE GRADE DATUM	DEPTH TO INVERT	H.G.L.	INVERT LEVEL	FINISHED SURFACE	EXISTING SURFACE	PIPE CHAINAGE (Reach Length)
0.036	0.131	1.85	3000	36.0	2.211	42.201	41.933	44.144	44.149	0.000
0.030	0.097	1.37	3000	36.0	2.156	42.303	42.008	44.289	44.289	19.248
0.017	0.097	1.37	3000	36.0	1.829	42.491	42.361	44.191	44.504	27.672
0.006	0.102	1.44	3000	36.0	1.779	42.514	42.411	44.197	44.608	44.548
					1.652	42.611	42.495	44.197	44.627	52.835
					1.504	42.813	42.714	44.218	44.627	
					1.454	42.824	42.764	44.252	44.627	
					1.396	42.913	42.856	44.252	44.627	
					1.633	42.958	42.856	44.252	44.627	
					1.588	43.033	42.958	44.252	44.627	
					1.407	43.248	43.033	44.252	44.627	
					1.357	43.434	43.248	44.252	44.627	
					1.400	43.484	43.484	44.252	44.627	
					1.829	43.515	43.484	44.252	44.627	
					1.779	43.515	43.484	44.252	44.627	
					1.400	42.862	42.823	44.252	44.627	
					1.794	42.854	42.823	44.252	44.627	
					1.744	42.880	42.823	44.252	44.627	
					1.400	43.108	43.035	44.252	44.627	
					43.112	43.108	43.035	44.252	44.627	
					0.972	40.520	40.732	42.022	42.010	
					0.897	40.595	41.176	42.022	42.010	
					0.896	41.282	41.126	42.022	42.010	
					0.846	41.423	41.176	42.022	42.010	
					0.900	41.305	41.305	42.205	42.205	
					1.679	40.601	40.391	42.009	42.015	
					1.604	40.776	40.411	42.009	42.015	
					1.598	40.777	40.414	42.086	42.015	
					1.601	40.777	40.414	42.086	42.015	
					1.601	40.414	40.414	42.086	42.015	
					1.749	40.856	40.575	42.325	42.325	
					1.749	40.856	40.575	42.325	42.325	
					1.769	40.865	40.600	42.369	42.375	
					40.933	40.865	40.600	42.369	42.375	

ISSUED FOR CONSTRUCTION

© COPYRIGHT All rights reserved Beveridge Williams & Co. Pty Ltd has granted a licence to the principle to use this document for its intended purpose. No unauthorised copying is permitted.									
REV	DESCRIPTION	DATE	DRN.	APP.	REV	DESCRIPTION	DATE	DRN.	APP.
A	ISSUED FOR CONSTRUCTION	24.02.22	M.F.	M.F.					

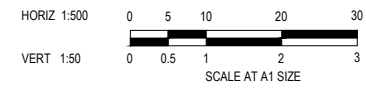

Designed Date: E. BARCHAM 02.08.2021
 Drawn: N. TABUENA
 Approved Date: M. FELICIANO 02.08.2021
 PS Number: PS848726W

BW Beveridge Williams
 1 Glenferrie Road
 Malvern VIC 3144
 ph: 03 9524 8888
 www.beveridgewilliams.com.au

Project Details: MERIDIAN CENTRAL ESTATE
 STAGE 31
 CITY OF CASEY

Drawing Title: DRAINAGE LONGITUDINAL SECTIONS
 (SHEET 2 OF 5)

Sheet 23 of 27
 Scale: 1:500 H 1:50 V @ A1
 Project Ref: 1801767
 Stage No: 31
 Drawing No: 401
 Rev: A

K:\Jobs Data\1801767 - Meridian_Eng\Stage 31\Drawings\1801767-31-400-DLS.dwg

NOTES:
 ALL STORMWATER DRAINS UP TO AND INCLUDING 750mm DIA. ARE TO BE CLASS 2 R.R.J. PIPES UNLESS NOTED OTHERWISE.

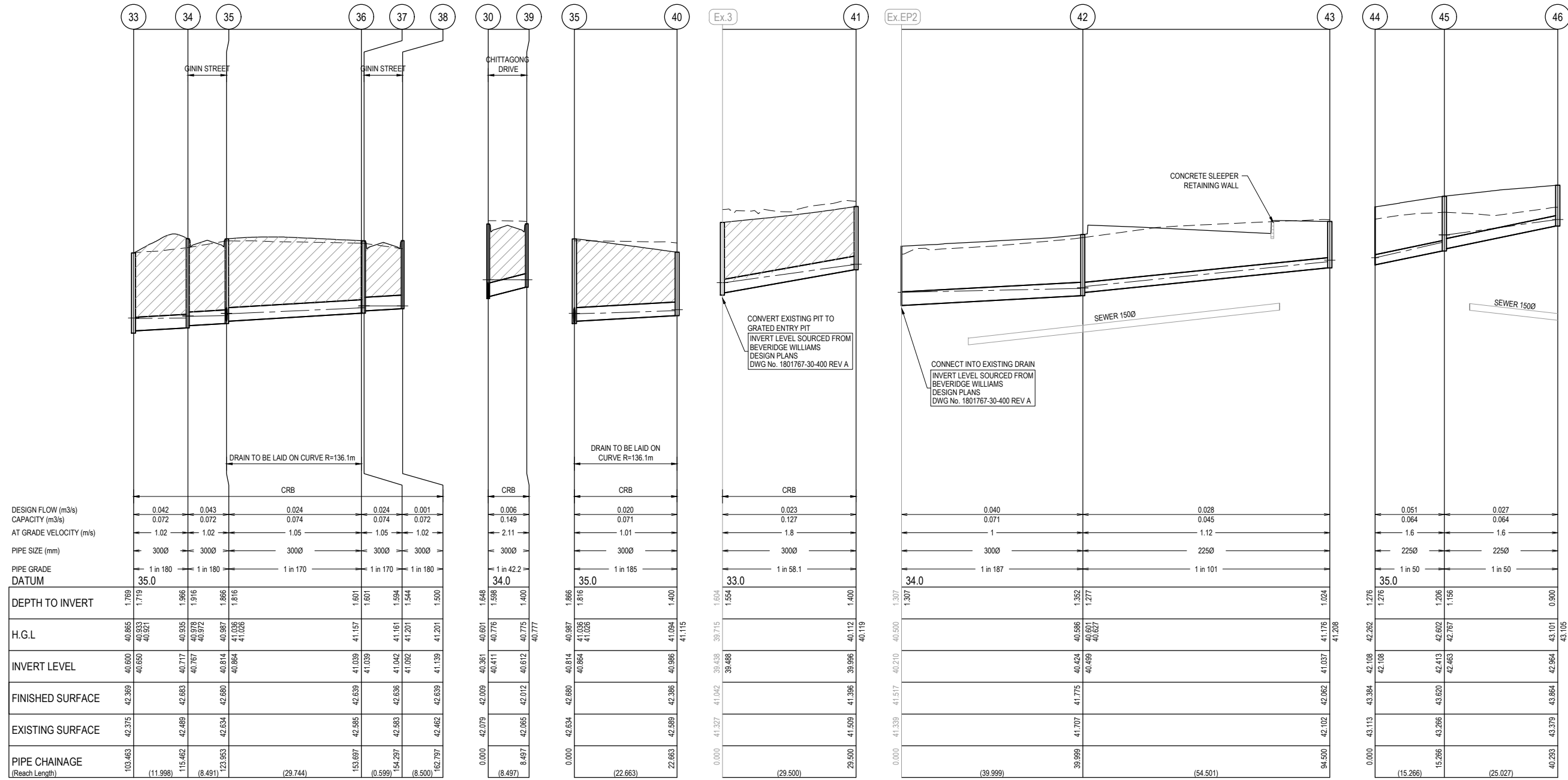
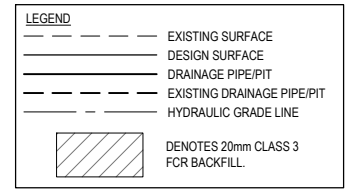

ISSUED FOR CONSTRUCTION

REV	DESCRIPTION	DATE	DRN.	APP.	REV	DESCRIPTION	DATE	DRN.	APP.
A	ISSUED FOR CONSTRUCTION	24.02.22	M.F.	M.F.					

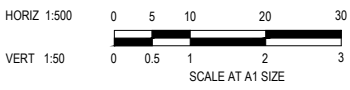

Designed Date: E. BARCHAM 02.08.2021
 Drawn: N. TABUENA
 Approved Date: M. FELICIANO 02.08.2021
 PS Number: PS848726W

BW Beveridge Williams
 1 Glenferrie Road
 Malvern VIC 3144
 ph: 03 9524 8888
 www.beveridgewilliams.com.au

Project Details: MERIDIAN CENTRAL ESTATE
 STAGE 31
 CITY OF CASEY

Drawing Title: DRAINAGE LONGITUDINAL SECTIONS
 (SHEET 3 OF 5)

Sheet 24 of 27
 Scale: 1:500 H 1:50 V @ A1
 Project Ref: 1801767
 Stage No: 31
 Drawing No: 402
 Rev: A

K:\Jobs Data\1801767 - Meridian_Eng\Stage 31\Drawings\1801767-31-400-DLS.dwg

NOTES:
 ALL STORMWATER DRAINS UP TO AND INCLUDING 750mm DIA. ARE TO BE CLASS 2 R.R.J. PIPES UNLESS NOTED OTHERWISE.

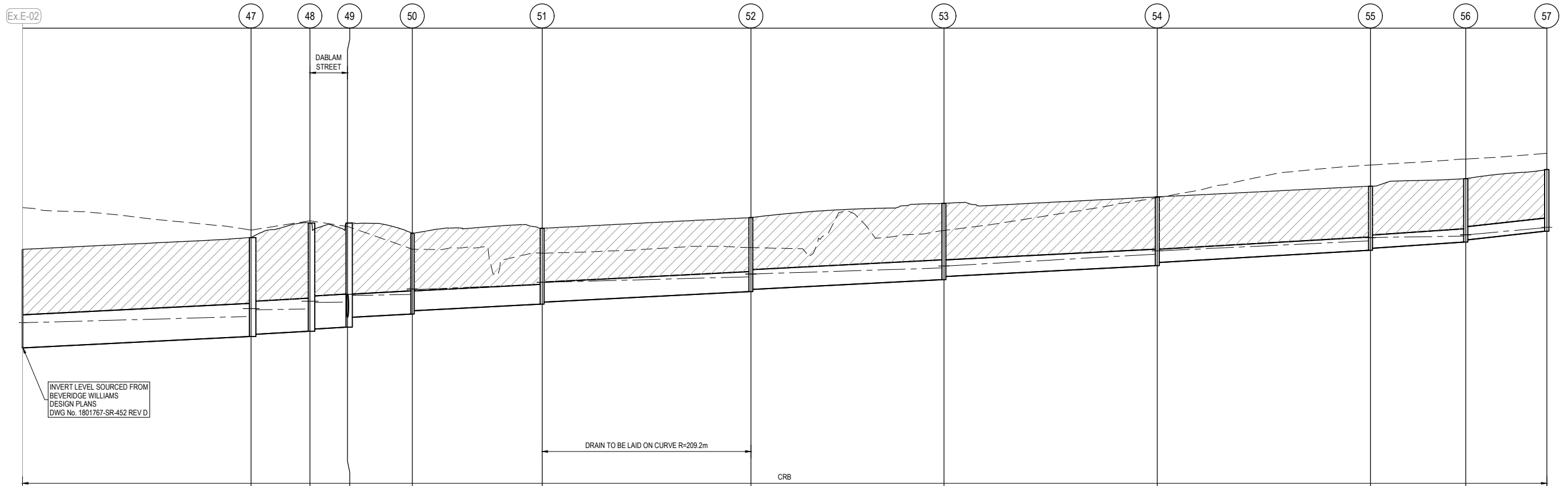
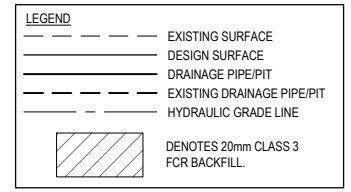

DESIGN FLOW (m3/s)	0.529	0.527	0.498	0.203	0.179	0.167	0.133	0.103	0.062	0.031	0.013
CAPACITY (m3/s)	0.788	0.788	0.788	0.304	0.202	0.202	0.202	0.124	0.073	0.078	0.099
AT GRADE VELOCITY (m/s)	1.78	1.78	1.78	1.41	1.27	1.27	1.27	1.12	1.03	1.1	1.4
PIPE SIZE (mm)	7500	7500	7500	5250	4500	4500	4500	3750	3000	3000	3000
PIPE GRADE	1 in 200	1 in 200	1 in 200	1 in 200	1 in 200	1 in 200	1 in 200	1 in 200	1 in 175	1 in 155	1 in 95.6
DATUM	35.0										
DEPTH TO INVERT	2.231	2.239	2.189	2.450	2.400	2.358	2.133	1.829	1.779	1.676	1.626
H.G.L.	40.653	40.773	40.942	41.063	41.102	41.500	41.672	41.874	41.917	41.918	1.400
INVERT LEVEL	40.064	40.372	40.439	40.489	40.532	41.101	41.252	41.338	41.602	41.682	1.400
FINISHED SURFACE	42.294	42.562	42.889	42.889	42.889	42.659	42.771	43.014	43.335	43.482	44.103
EXISTING SURFACE	43.228	42.729	42.941	42.815	42.815	42.209	42.771	43.014	43.335	43.482	44.103
PIPE CHAINAGE (Reach Length)	0.000	51.786	(13.334)	65.120	(8.498)	73.618	(14.674)	88.292	(29.421)	117.713	(47.280)
								164.993	(43.721)	208.714	(48.329)
										267.042	(48.309)
										305.351	(21.562)
										326.913	(18.367)
										345.281	

ISSUED FOR CONSTRUCTION

© COPYRIGHT All rights reserved Beveridge Williams & Co. Pty Ltd has granted a licence to the principle to use this document for its intended purpose. No unauthorised copying is permitted.						
REV	DESCRIPTION	DATE	DRN.	APP.	REV	DESCRIPTION
A	ISSUED FOR CONSTRUCTION	24.02.22	M.F.	M.F.		

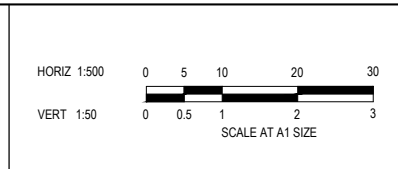

Designed Date: E. BARHAM 02.08.2021
 Drawn: N. TABUENA
 Approved Date: M. FELICIANO 02.08.2021
 PS Number: PS848726W



Project Details: MERIDIAN CENTRAL ESTATE STAGE 31 CITY OF CASEY
 Drawing Title: DRAINAGE LONGITUDINAL SECTIONS (SHEET 4 OF 5)

Sheet 25 of 27			
Scale 1:500 H 1:50 V @ A1			
Project Ref	Stage No	Drawing No	Rev
1801767	31	403	A

NOTES:
 ALL STORMWATER DRAINS UP TO AND INCLUDING 750mm DIA. ARE TO BE CLASS 2 R.R.J. PIPES UNLESS NOTED OTHERWISE.

LEGEND	
	EXISTING SURFACE
	DESIGN SURFACE
	DRAINAGE PIPE/PIT
	EXISTING DRAINAGE PIPE/PIT
	HYDRAULIC GRADE LINE
	DENOTES 20mm CLASS 3 FCR BACKFILL

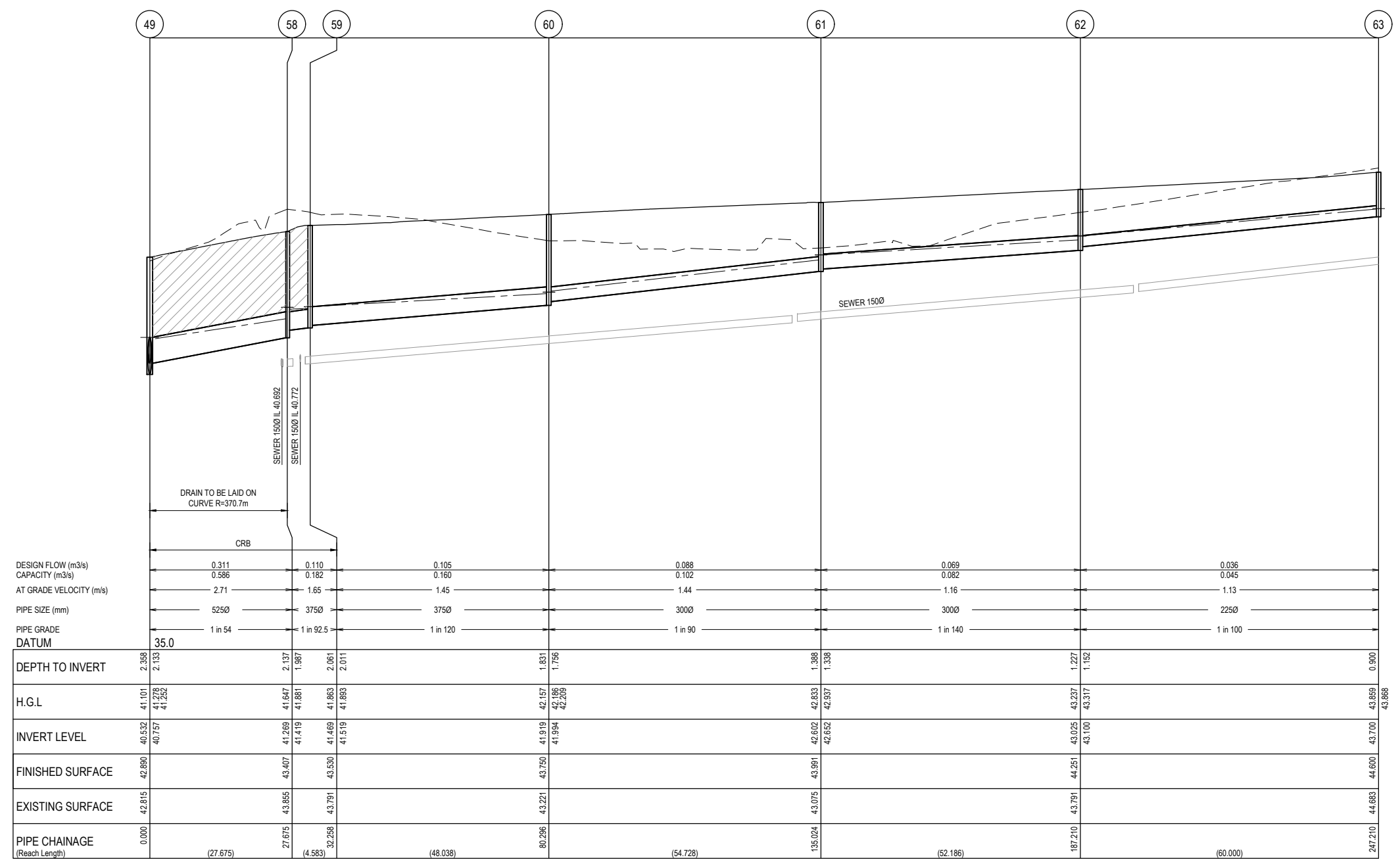

ISSUED FOR CONSTRUCTION

© COPYRIGHT All rights reserved Beveridge Williams & Co. Pty Ltd has granted a licence to the principle to use this document for its intended purpose. No unauthorised copying is permitted.									
REV	DESCRIPTION	DATE	DRN.	APP.	REV	DESCRIPTION	DATE	DRN.	APP.
A	ISSUED FOR CONSTRUCTION	24.02.22	M.F.	M.F.					

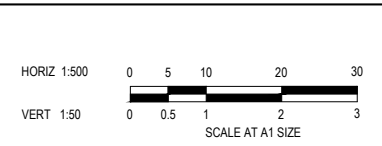
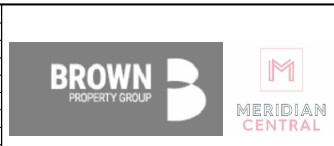

Designed Date: E. BARCHAM 02.08.2021
 Drawn: N. TABUENA
 Approved Date: M. FELICIANO 02.08.2021
 PS Number: PS848726W



Project Details: MERIDIAN CENTRAL ESTATE STAGE 31 CITY OF CASEY
 Drawing Title: DRAINAGE LONGITUDINAL SECTIONS (SHEET 5 OF 5)

Sheet 26 of 27			
Scale: 1:500 H 1:50 V @ A1			
Project Ref	Stage No	Drawing No	Rev
1801767	31	404	A

PIT NUMBER	TYPE	PIT SCHEDULE										REMARKS
		INTERNAL		INLET		OUTLET		F.S.L.	DEPTH	STANDARD DRAWING		
		WIDTH (mm)	LENGTH (mm)	DIAMETER (mm)	INV R.L. (m)	DIAMETER (mm)	INV R.L. (m)					
Ex.14				450	39.962			41.628	1.666			CONNECT TO EXISTING ENDPIPE
2	TANGENT POINT			450	40.010	450	40.010	41.686	1.676			
3	JUNCTION PIT	750	900	450	40.420	450	40.370	42.273	1.903	EDCM 605 & 607		HAUNCH PIT COVER TO 600 x 900
				300	40.520							
4	GRADED ENTRY PIT	600	1050	450	40.550	450	40.500	42.213	1.713	EDCM 601 & 607		HAUNCH PIT COVER TO 600 x 900
5	GRADED ENTRY PIT	750	1050	375	40.711	450	40.636	42.433	1.797	EDCM 601 & 607		HAUNCH PIT COVER TO 600 x 900
				300	40.786							
6	GRADED PIT	600	900	375	40.911	375	40.861	42.647	1.786	EDCM 605		INSTALL 600x900 ECO-WEAVED FLAT GRATE OR APPROVED EQUIVALENT FOR RAINGARDEN
7	GRADED ENTRY PIT	600	900	375	41.392	375	41.342	43.129	1.787	EDCM 601		
				225	41.492							
8	JUNCTION PIT	600	900	375	41.761	375	41.711	43.679	1.967	EDCM 605		
9	GRADED ENTRY PIT	600	900	300	42.008	375	41.933	44.142	2.209	EDCM 601		
				300	42.008							
10	GRADED ENTRY PIT	600	900	300	42.402	300	42.352	44.324	1.972	EDCM 601		
10A	GRADED ENTRY PIT	600	900	300	42.682	300	42.632	44.426	1.794	EDCM 601		
				300	42.682							
11	JUNCTION PIT	600	900	300	42.798	300	42.748	44.459	1.711	EDCM 605		
12	JUNCTION PIT	600	900	300	43.033	300	42.958	44.591	1.633	EDCM 605		PROVIDE BLOCKOUT IN EAST WALL FOR FUTURE 300mm DRAIN IL43.00
				225	43.033							
16	GRADED PIT	600	900	300	41.278	300	41.228	42.667	1.439	EDCM 605		INSTALL 600x900 ECO-WEAVED FLAT GRATE OR APPROVED EQUIVALENT FOR RAINGARDEN
17	JUNCTION PIT	600	900	300	42.127	300	42.095	43.495	1.400	EDCM 605		INSTALL HEAVY DUTY COVER
17A	GRADED ENTRY PIT	600	900			300	42.228	43.628	1.400	EDCM 601		
18	GRADED ENTRY PIT	600	900			300	41.107	42.507	1.400	EDCM 601		
19	JUNCTION PIT	600	900			225	42.870	43.869	1.000	EDCM 605		
20	GRADED ENTRY PIT	600	900	300	42.411	300	42.361	44.191	1.829	EDCM 601		
				300	42.411							
21	GRADED ENTRY PIT	600	900	300	42.545	300	42.495	44.197	1.702	EDCM 601		
22	GRADED ENTRY PIT	600	900	300	42.764	300	42.714	44.222	1.508	EDCM 601		
23	JUNCTION PIT	600	900			300	42.856	44.256	1.400	EDCM 605		
24	JUNCTION PIT	600	900	225	43.484	225	43.434	44.840	1.407	EDCM 605		
25	JUNCTION PIT	600	900			225	43.925	44.925	1.000	EDCM 605		
26	GRADED ENTRY PIT	600	900			300	42.823	44.222	1.400	EDCM 601		
27	GRADED ENTRY PIT	600	900			300	43.035	44.435	1.400	EDCM 601		
Ex EP1	JUNCTION PIT	600	900	225	40.595			41.492	0.972	EDCM 605		CONSTRUCT JUNCTION PIT OVER EXISTING DRAINAGE
28	JUNCTION PIT	600	900	225	41.176	225	41.126	42.022	0.896	EDCM 605		
29	JUNCTION PIT	600	900			225	41.305	42.205	0.900	EDCM 605		
Ex.1A	GRADED ENTRY PIT	600	900	300	39.474			41.078	1.679	EDCM 601		CONVERT EXISTING JUNCTION PIT TO GRADED ENTRY PIT AND CONNECT DRAINAGE
30	GRADED ENTRY PIT	600	900	300	40.411	300	40.361	42.009	1.648	EDCM 601		
				300	40.411							
31	TANGENT POINT			300	40.414	300	40.414	42.015	1.601			
32	TANGENT POINT			300	40.575	300	40.575	42.325	1.749			
33	GRADED ENTRY PIT	600	900	300	40.650	300	40.600	42.369	1.769	EDCM 601		
34	JUNCTION PIT	600	900	300	40.767	300	40.717	42.683	1.966	EDCM 605		
35	JUNCTION PIT	600	900	300	40.864	300	40.814	42.680	1.866	EDCM 605		
				300	40.864							
36	TANGENT POINT			300	41.039	300	41.039	42.639	1.601			
37	JUNCTION PIT	600	900	300	41.092	300	41.042	42.636	1.594	EDCM 605		
38	JUNCTION PIT	600	900			300	41.139	42.639	1.500	EDCM 605		HOUSE DRAIN TO BE CONSTRUCTED AT IL41.34 AND GRADED MIN. @ 1 in 60 TO CORNER OF SUBSTATION SITE. ENSURE VERTICAL CLEARANCES TO HV AND LV ARE MET
39	GRADED ENTRY PIT	600	900			300	40.612	42.012	1.400	EDCM 601		
40	GRADED ENTRY PIT	600	900			300	40.986	42.386	1.400	EDCM 601		
Ex.3	GRADED ENTRY PIT	600	900	300	39.488			41.042	1.604	EDCM 601		CONVERT EXISTING JUNCTION PIT TO GRADED ENTRY PIT AND CONNECT DRAINAGE
41	JUNCTION PIT	600	900	300	39.996	300	39.996	41.396	1.400			
Ex EP2	END PIPE			300	40.210			41.517	1.307			CONNECT INTO EXISTING DRAIN
42	JUNCTION PIT	600	900	225	40.499	300	40.424	41.775	1.352	EDCM 605		
43	JUNCTION PIT	600	900			225	41.037	42.062	1.024	EDCM 605		
44	END PIPE			225	42.108			43.384	1.276			CAP END PIPE FOR CONNECTION
45	JUNCTION PIT	600	900	225	42.463	225	42.413	43.620	1.206	EDCM 605		
46	JUNCTION PIT	600	900			225	42.964	43.864	0.900	EDCM 605		
Ex.E-02	END PIPE			750	40.064			42.294	2.231			CONNECT INTO EXISTING DRAIN
47	JUNCTION PIT	1050	1350	750	40.372	750	40.322	42.562	2.239	EDCM 605 & 607		HAUNCH PIT COVER TO 600 x 900. PROVIDE BLOCKOUT IN WEST WALL FOR FUTURE 300mm DRAIN. IL 40.77. TO BE CONVERTED INTO DOUBLE GRADED ENTRY PIT IN STAGE 33
48	JUNCTION PIT	600	1350	750	40.489	750	40.439	42.889	2.450	EDCM 605 & 607		HAUNCH PIT COVER TO 600 x 900. TO BE CONVERTED INTO DOUBLE GRADED ENTRY PIT IN STAGE 33
49	JUNCTION PIT	900	900	525	40.757	750	40.532	42.890	2.358	EDCM 605 & 607		HAUNCH PIT COVER TO 600 x 900. TO BE CONVERTED INTO DOUBLE GRADED ENTRY PIT IN STAGE 33
				525	40.757							
50	JUNCTION PIT	750	900	450	40.905	525	40.830	42.659	1.829	EDCM 605 & 607		HAUNCH PIT COVER TO 600 x 900. PROVIDE BLOCKOUT IN WEST WALL FOR FUTURE 300mm DRAIN. IL 41.05. TO BE CONVERTED INTO GRADED ENTRY PIT IN STAGE 33
51	JUNCTION PIT	750	900	450	41.102	450	41.052	42.771	1.719	EDCM 605 & 607		HAUNCH PIT COVER TO 600 x 900. TO BE CONVERTED INTO GRADED ENTRY PIT IN STAGE 33
52	JUNCTION PIT	750	900	450	41.388	450	41.338	43.014	1.676	EDCM 605 & 607		HAUNCH PIT COVER TO 600 x 900. PROVIDE BLOCKOUT IN WEST WALL FOR FUTURE 300mm DRAIN. IL 41.49. TO BE CONVERTED INTO GRADED ENTRY PIT IN STAGE 33
53	JUNCTION PIT	750	900	375	41.682	450	41.607	43.335	1.728	EDCM 605 & 607		HAUNCH PIT COVER TO 600 x 900. PROVIDE BLOCKOUT IN WEST WALL FOR FUTURE 300mm DRAIN. IL 41.76. TO BE CONVERTED INTO GRADED ENTRY PIT FOR THE RAINGARDEN IN STAGE 32
54	JUNCTION PIT	600	900	300	41.999	375	41.924	43.482	1.559	EDCM 605		PROVIDE BLOCKOUT IN WEST WALL FOR FUTURE 300mm DRAIN. IL 42.00. TO BE CONVERTED INTO GRADED ENTRY PIT IN STAGE 32
55	JUNCTION PIT	600	900	300	42.321	300	42.275	43.724	1.449	EDCM 605		PROVIDE BLOCKOUT IN WEST WALL FOR FUTURE 300mm DRAIN. IL 42.32. TO BE CONVERTED INTO GRADED ENTRY PIT IN STAGE 32
56	GRADED ENTRY PIT	600	900	300	42.511	300	42.461	43.896	1.435	EDCM 601		
57	GRADED ENTRY PIT	600	900	300	42.703	300	42.703	44.103	1.400	EDCM 601		
58	JUNCTION PIT	750	900	375	41.419	525	41.269	43.407	2.137	EDCM 605 & 607		HAUNCH PIT COVER TO 600 x 900. PROVIDE BLOCKOUT IN EAST WALL FOR FUTURE 450mm DRAIN. IL 41.34
59	JUNCTION PIT	600	900	375	41.519	375	41.469	43.530	2.061	EDCM 605		
60	JUNCTION PIT	600	900	300	41.994	375	41.919	43.750	1.831	EDCM 605		
61	JUNCTION PIT	600	900	300	42.652	300	42.602	43.991	1.388	EDCM 605		
62	JUNCTION PIT	600	900	225	43.100	300	43.025	44.251	1.227	EDCM 605		
63	JUNCTION PIT	600	900			225	43.700	44.600	0.900	EDCM 605		

ISSUED FOR CONSTRUCTION

© COPYRIGHT All rights reserved
Beveridge Williams & Co. Pty Ltd has granted a licence to the principle to use this document for its intended purpose.
No unauthorised copying is permitted

REV	DESCRIPTION	DATE	DRN.	APP.	REV	DESCRIPTION	DATE	DRN.	APP.
A	ISSUED FOR CONSTRUCTION	24.02.22	M.F	M.F					

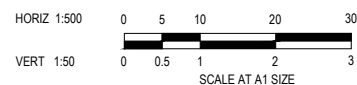

Designed Date
E. BARCHAM
02.08.2021

Drawn
N. TABUENA

Approved Date
M. FELICIANO
02.08.2021

PS Number
PS848726W



Project Details
MERIDIAN CENTRAL ESTATE
STAGE 31
CITY OF CASEY

Drawing Title
PIT SCHEDULE

Sheet 27 of 27

Scale
1:500 H 1:50 V @ A1

Project Ref
1801767

Stage No
31

Drawing No
405

Rev
A